

## High Efficiency 1.2MHz 28V 2A Step-up DC/DC Converter

### DESCRIPTION

The BL8042B is a constant frequency, current mode step-up converter intended for small, low power applications. The BL8042B switches at 1.2MHz and allows the use of tiny, low cost capacitors and inductors 2mm or less in height. Internal soft-start results in small inrush current and extends battery life.

The BL8042B includes under-voltage lockout, current limiting, and thermal overload protection to prevent damage in the event of an output overload.

BL8042B is available in SOT23-6 package that is PB free.

### TYPICAL APPLICATION

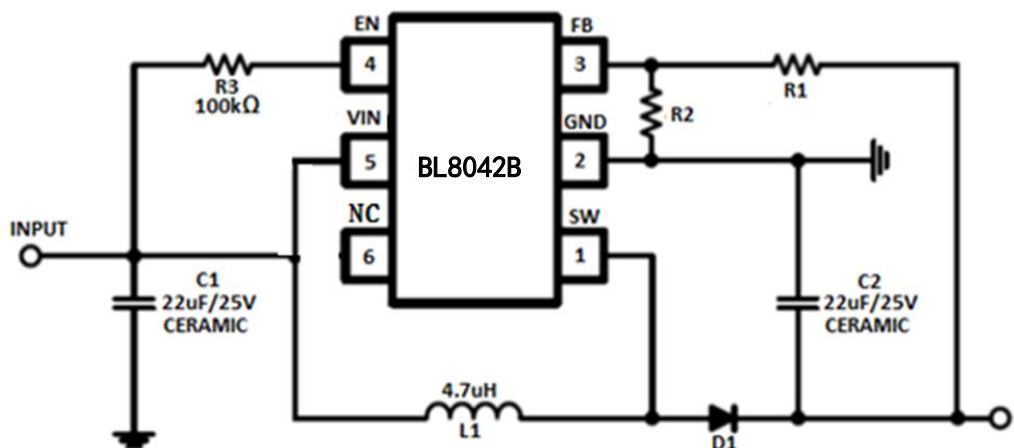

Figure1. BL8042B typical application circuit

### FEATURES

- 2V to 24V input voltage
- Up to 28V output voltage
- Integrated 80mΩ power MOSFET
- 1.2MHz fixed switching frequency
- Internal 4A switch current limit
- Internal compensation
- Thermal shutdown
- Output adjustable from 0.6V
- Available in SOT23-6 package

### APPLICATIONS

- ABS set-top boxed
- DVB-S/S2

### ORDERING INFORMATION

BL8042B [1](#) [2](#) [3](#)

Code	Description
1	Temperature & Rohs: C: -40~85°C, Pb free rohs std.
2	Package type: B6: SOT-23-6
3	Packing type: TR: tape & reel (standard)

### MARKING INFORMATION

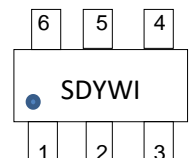
Product classification		BL8042BCB6TR
Marking		
SDYWI	SD: product code	
	YW: date code	

## PIN DESCRIPTION

Pin No.	Symbol	Description
1	SW	Power switch output. SW is the drain of the internal MOSFET switch. Connect the power inductor and output rectifier to SW. SW can swing between GND and 28V.
2	GND	Ground.
3	FB	Feedback input. The FB voltage is 0.6V. Connect a resistor divider to FB.
4	EN	Regulator On/Off control input. A high input at EN turns on the converter, and a low input turns it off. When not used, connect EN to the input supply for automatic startup.
5	VIN	Power supply. Must be locally bypassed.
6	NC	No connection

## ABSOLUTE MAXIMUM RATING

Parameter	Value
VIN, EN pin voltage	-0.3V to 26V
SW pin voltage	-0.3V to 26V
All other pin voltage	-0.3V to 6V
Junction temperature (T <sub>J</sub> )	150°C
Operating ambient temperature (T <sub>A</sub> )	-40°C to 85°C
Power dissipation	600mW
Thermal resistance (θ <sub>JA</sub> )	SOT23-6
Thermal resistance (θ <sub>JC</sub> )	
Storage temperature (T <sub>S</sub> )	130°C/W
Lead temperature & time	-65°C to 150°C
	260°C, 10Sec

## RECOMMENDED WORK CONDITIONS

Parameter	Value
Input voltage range	2V to 24V
Output voltage range	VIN to 28V
Operating junction temperature(T <sub>J</sub> )	-40°C –125°C

## ELECTRICAL CHARACTERISTICS

(T<sub>a</sub>=25°C, unless otherwise noted)

Symbol	Item	Conditions	Min.	Typ.	Max.	Unit
V <sub>IN</sub>	Operating input voltage		2		24	V
V <sub>FB</sub>	Feedback voltage		588	600	612	mV
I <sub>FB</sub>	FB input bias current	V <sub>FB</sub> =0.6V	-50	-10		nA
	SW leakage	V <sub>SW</sub> =20V			1	uA
I <sub>Q</sub>	Quiescent current	V <sub>FB</sub> =0.8V, No switch		0.25	0.5	mA
		V <sub>EN</sub> =0V		0.1	1	uA
F <sub>SW</sub>	Oscillator frequency	V <sub>FB</sub> =0.75V		1.2		MHz
D <sub>MAX</sub>	Maximum duty cycle	V <sub>FB</sub> =0.7V		90		%
V <sub>EN</sub>	EN threshold			1		V
	SW on-resistance			80	150	mΩ
I <sub>LIMIT</sub>	Current limit	V <sub>IN</sub> =5V, Duty cycle = 50%		4		A
	Thermal shutdown			160		°C

## TYPICAL PERFORMANCE CHARACTERISTICS

**Efficiency vs. Output Current  
(Vout=5V)**

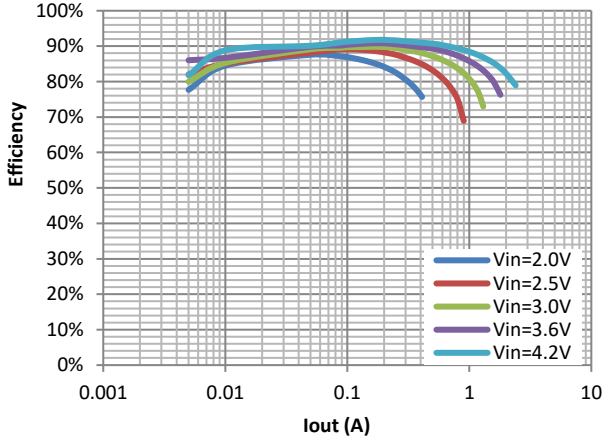

**Efficiency vs. Output Current  
(Vout=14V)**

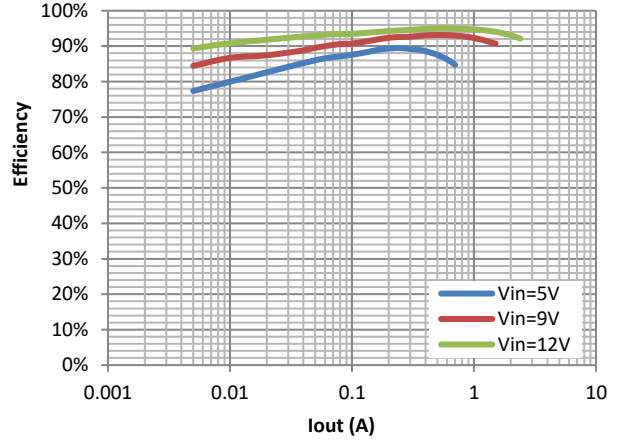

**Efficiency vs. Output Current  
(Vout=19V)**

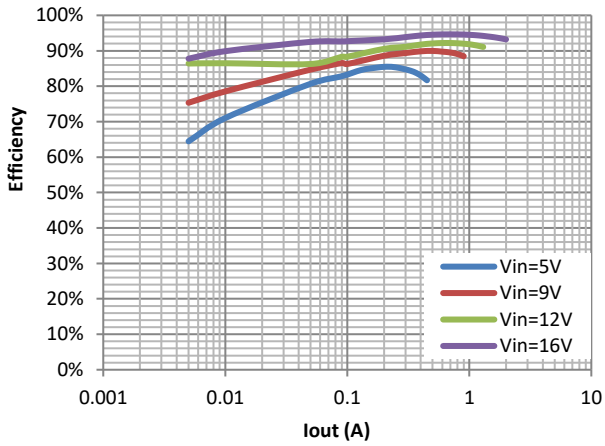

**Load Regulation  
(Vout=5V)**

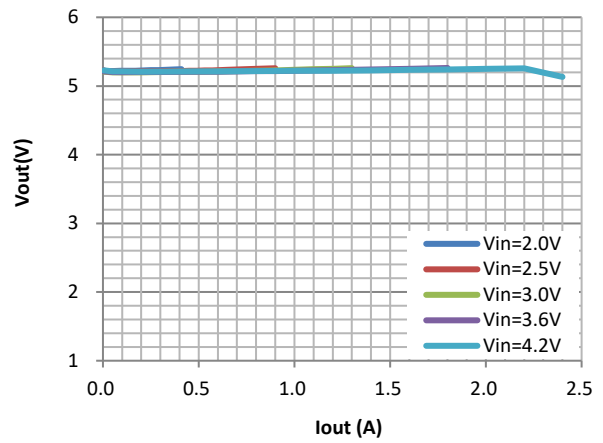

**Load Regulation  
(Vout=14V)**

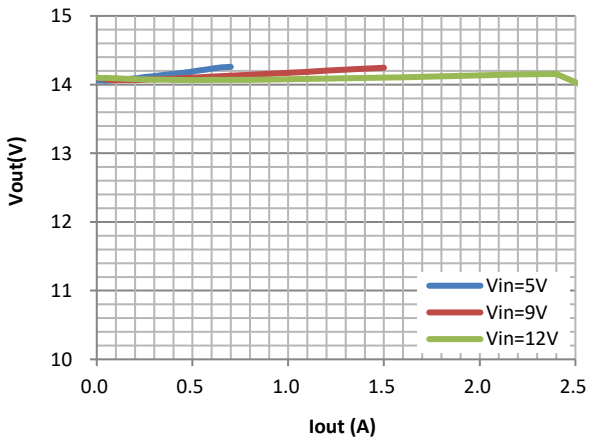

**Load Regulation  
(Vout=19V)**

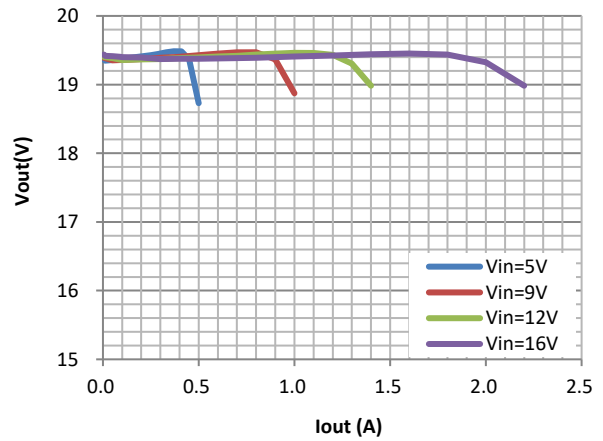

### Line Regulation

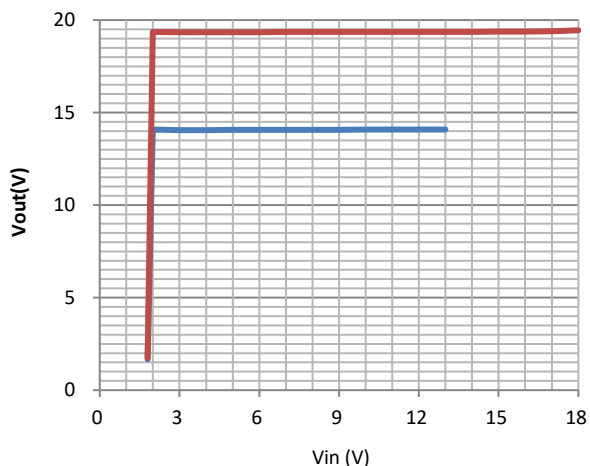

### Vout vs. Temperature

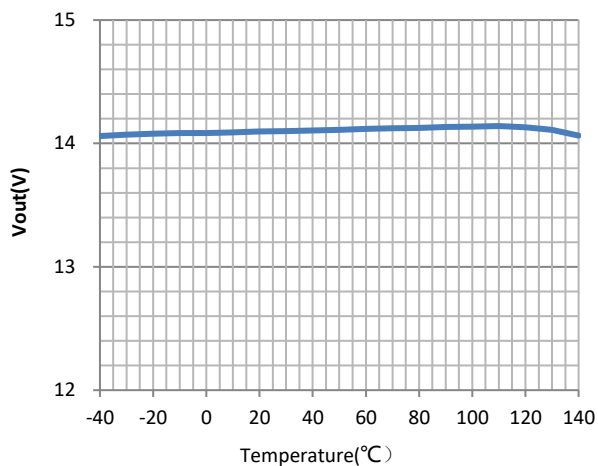

## BLOCK DIAGRAM

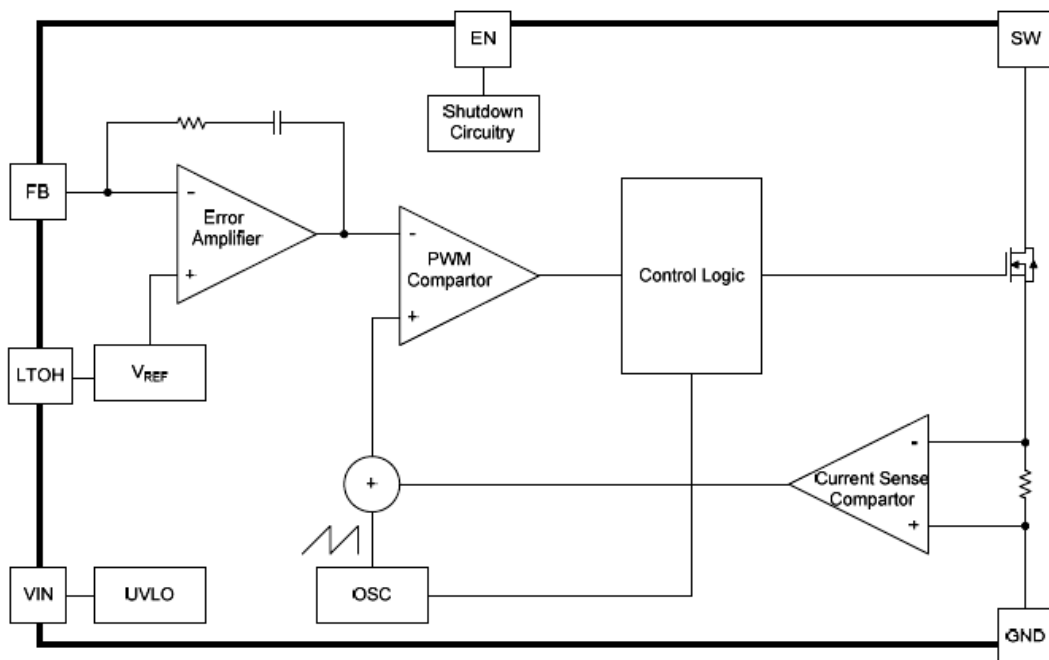

## DETAILED DESCRIPTION

The BL8042B uses a fixed frequency, peak current mode boost regulator architecture to regulate voltage at the feedback pin. The operation of the BL8042B can be understood by referring to the block diagram of Figure 3. At the start of each oscillator cycle the MOSFET is turned on through the control circuitry. To prevent sub-harmonic oscillations at duty cycles greater than 50 percent, a stabilizing ramp is added to the output of the current sense amplifier and the result is fed into the negative input of the PWM comparator. When this voltage equals the output voltage of the error amplifier the power MOSFET is turned off. The voltage at the output of the error amplifier is an amplified version of the difference between the 0.6V band gap reference voltage and the feedback voltage. In this way the peak current level keeps the output in regulation. If the feedback voltage starts to drop, the output of the error amplifier increases. These results in more current to flow through the power MOSFET, thus increasing the power delivered to the output. The BL8042B has internal soft start to limit the amount of input current at startup and to also limit the amount of overshoot on the output.

## APPLICATION INFORMATION

### **Setting the output voltage**

The internal reference VREF is 0.6V (Typical). The output voltage is divided by a resistor divider, R1 and R2 to the FB pin. The output voltage is given by

$$V_{OUT} = V_{REF} \times \left(1 + \frac{R_1}{R_2}\right)$$

### **Inductor selection**

The recommended values of inductor are 4.7 to 22μH. Small size and better efficiency are the major concerns for portable device, such as BL8042B used for mobile phone. The inductor should have low core loss at 1.2MHz and low DCR for better efficiency. To avoid inductor saturation current rating should be considered.

### **Capacitor selection**

Input and output ceramic capacitors of 22μF are recommended for BL8042B applications. For better voltage filtering, ceramic capacitors with low ESR are recommended. X5R and X7R types are suitable because of their wider voltage and temperature ranges.

### **Diode selection**

Schottky diode is a good choice for BL8042B because of its low forward voltage drop and fast reverse recovery. Using Schottky diode can get better efficiency. The high speed rectification is

also a good characteristic of Schottky diode for high switching frequency. Current rating of the diode must meet the root mean square of the peak current and output average current multiplication as following:

$$I_D(RMS) \approx \sqrt{I_{OUT} \times I_{PEAK}}$$

The diode's reverse breakdown voltage should be larger than the output voltage.

### **Layout consideration**

When laying out the printed circuit board, the following checking should be used to ensure proper operation of the BL8042B.

Check the following in your layout:

- 1) The power traces, consisting of the GND trace, the SW trace and the VIN, trace should be kept short, direct and wide.
- 2) Does the (+) plates of Cin connect to Vin as closely as possible. This capacitor provides the AC current to the internal power MOSFETs.
- 3) Keep the switching node SW away from the sensitive VOUT node.
- 4) Keep the (-) plates of Cin and Cout as close as possible

## PACKAGE INFORMATION

Package	SOT-23-6	Devices per reel	3000Pcs	Unit	mm
Package dimension:					
<p>The technical drawing illustrates the SOT-23-6 package dimensions. The top view shows a rectangular body with a total width of <math>2.9 \pm 0.2</math> mm and a central width of <math>1.9 \pm 0.2</math> mm. The distance between the centerlines of the two inner leads is <math>0.95</math> mm, and the distance between the centerlines of the two outer leads is also <math>0.95</math> mm. The lead lengths are <math>0.4 \pm 0.1</math> mm for the inner leads and <math>1.6 \pm 0.2</math> mm for the outer leads. The total height of the package is <math>2.8 \pm 0.3</math> mm. The side view shows a lead width of <math>1.1 \pm 0.2</math> mm, a lead thickness of <math>0.8 \pm 0.1</math> mm, and a lead height of <math>0.15 \pm 0.1</math> mm. The lead angle is specified as <math>0</math> to <math>0.1</math> degrees. The minimum lead length is <math>0.2</math> mm. The perspective view shows the package from an isometric angle.</p>					