

1. Description

➤ Advantages

The BLM2305 uses advanced trench technology to provide excellent $R_{DS(ON)}$, low gate charge and operation with gate voltages as low as 0.7V. This device is suitable for use as a wide variety of applications.

➤ Key Characteristics

Parameter _{SOT23-6}	Value	Unit
V_{DS}	-20	V
I_D	-4.5	A
$R_{DS(ON)}@4.5V_{.Typ}$	39	mΩ

➤ Features

- High power and current handing capability
- Lead free product is acquired
- RoHS product
- Surface mount package

➤ Applications

- PWM applications
- Load switch
- Power management



Schematic diagram

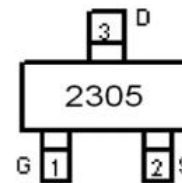

Marking and pin assignment

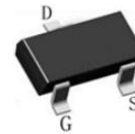

Top view

➤ Ordering Informations

Device Marking	Ordering Codes	Package	Product Code	Packing
2305	BLM2305	SOT-23	BLM2305	Reel

BLM2305

BLM2305:-20V 52mΩ

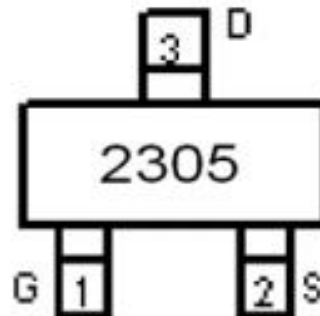

2. Absolute Ratings

at $T_C = 25^\circ\text{C}$, unless otherwise specified

Symbol	Parameter	Rating	Units
V_{DSS}	Drain-to-Source Voltage	-20	V
I_D	Continuous Drain Current	-4.5	A
	Continuous Drain Current $T_C = 100^\circ\text{C}$	-3	A
I_{DM}	Pulsed Drain Current(Note1)	-18	A
P_D	Power Dissipation	1.7	W
V_{GS}	Gate-to-Source Voltage	± 12	V
T_J, T_{stg}	Operating Junction and Storage Temperature Range	150, -55 to 150	$^\circ\text{C}$

3. Thermal Characteristics

Symbol	Parameter	Rating	Units
$R_{\theta JA}$	Junction-to-Ambient	74	$^\circ\text{C}/\text{W}$

4. Electrical Characteristics

at $T_C = 25^\circ\text{C}$, unless otherwise specified

OFF Characteristics

Symbol	Parameter	Test Conditions	Values			Units
			Min.	Typ.	Max.	
V_{DSS}	Drain to Source Breakdown Voltage	$V_{GS}=0\text{V}, I_D=-250\mu\text{A}$	-20	--	--	V
I_{DSS}	Drain to Source Leakage Current	$V_{DS}=-20\text{V}, V_{GS}=0\text{V}$	--	--	-1	μA
I_{GSS}	Gate to Source Forward Leakage	$V_{GS}=\pm 12\text{V}$	--	--	± 100	nA

ON Characteristics

Symbol	Parameter	Test Conditions	Values			Units
			Min.	Typ.	Max.	
$R_{DS(ON)}$	Drain-to-Source On-Resistance	$V_{GS}=-4.5\text{V}, I_D=-4\text{A}(\text{Note}2)$	--	39	52	m Ω
		$V_{GS}=-2.5\text{V}, I_D=-3\text{A}(\text{Note}2)$	--	55	70	m Ω
$V_{GS(TH)}$	Gate Threshold Voltage	$V_{DS} = V_{GS}, I_D=-250\mu\text{A}$	-0.4	-0.7	-1.0	V

Dynamic Characteristics

Symbol	Parameter	Test Conditions	Values			Units
			Min.	Typ.	Max.	
C_{iss}	Input Capacitance	$V_{GS} = 0V$ $V_{DS} = -4V$ $f = 1.0MHz$	--	740	--	pF
C_{oss}	Output Capacitance		--	290	--	
C_{rss}	Reverse Transfer Capacitance		--	190	--	

Switching Characteristics

Symbol	Parameter	Test Conditions	Values			Units
			Min.	Typ.	Max.	
$t_{d(ON)}$	Turn-on Delay Time	$I_D = -3.3A$ $V_{DD} = -4V$ $V_{GS} = -4.5V$ $R_G = 1\Omega$	--	12	--	ns
t_r	Rise Time		--	35	--	
$t_{d(OFF)}$	Turn-Off Delay Time		--	30	--	
t_f	Fall Time		--	10	--	
Q_g	Total Gate Charge	$I_D = -4.5A$ $V_{DD} = -4V$ $V_{GS} = -4.5V$	--	7.8	--	nC
Q_{gs}	Gate to Source Charge		--	1.2	--	
Q_{gd}	Gate to Drain ("Miller") Charge		--	1.6	--	

Source-Drain Diode Characteristics

Symbol	Parameter	Test Conditions	Values			Units
			Min.	Typ.	Max.	
I_S	Continuous Source Current (Body Diode)	$T_C = 25\text{ }^\circ\text{C}$	--	--	-4.5	A
V_{SD}	Diode Forward Voltage	$I_S = -4A$, $V_{GS} = 0V$	--	--	-1.2	V

Note1: Pulse width limited by maximum junction temperature

Note2: Pulse width $t_p \leq 300\mu s$, $\delta \leq 2\%$

5. Characteristics Curves

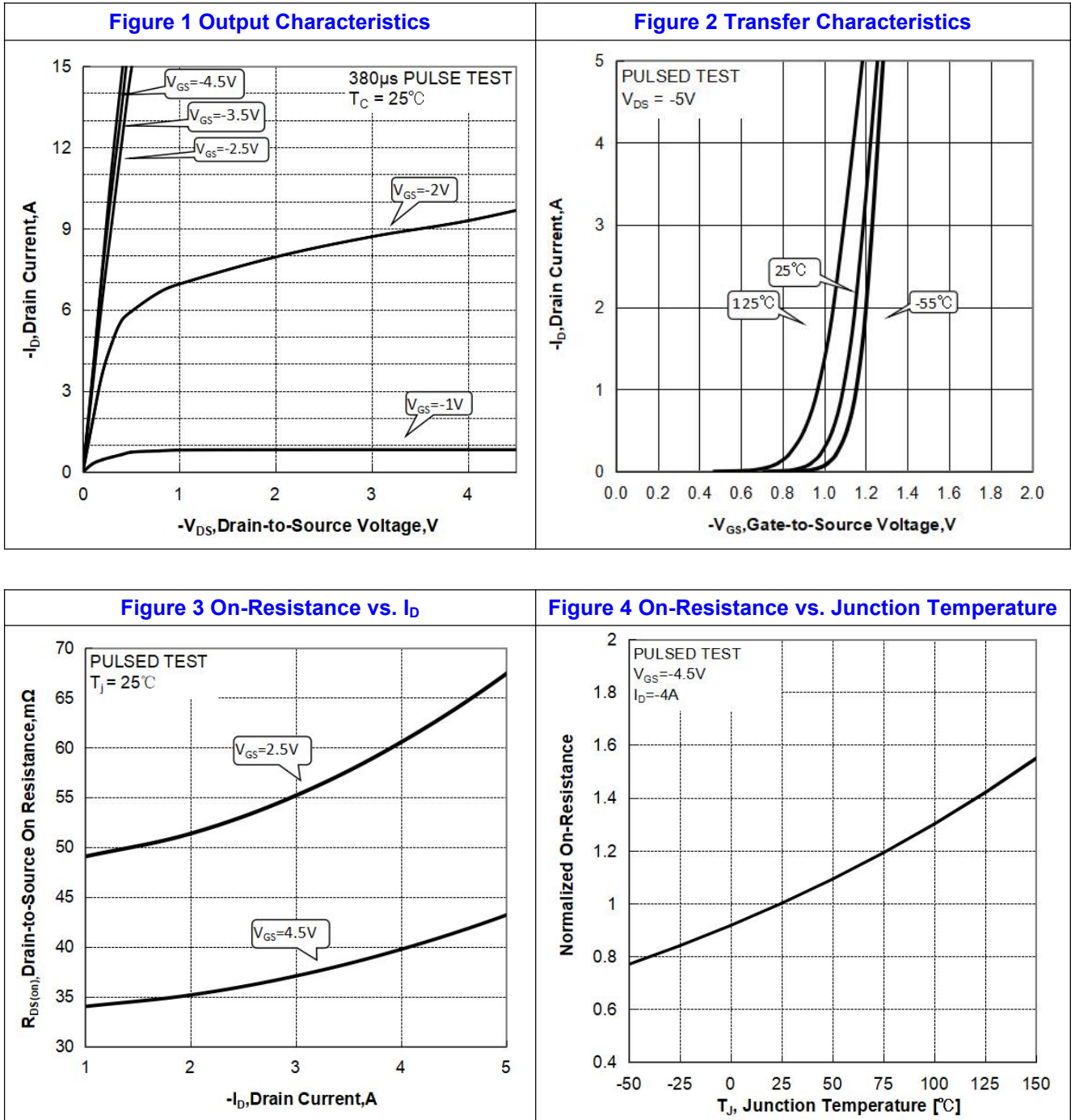

Figure 5 BV vs Junction Temperature

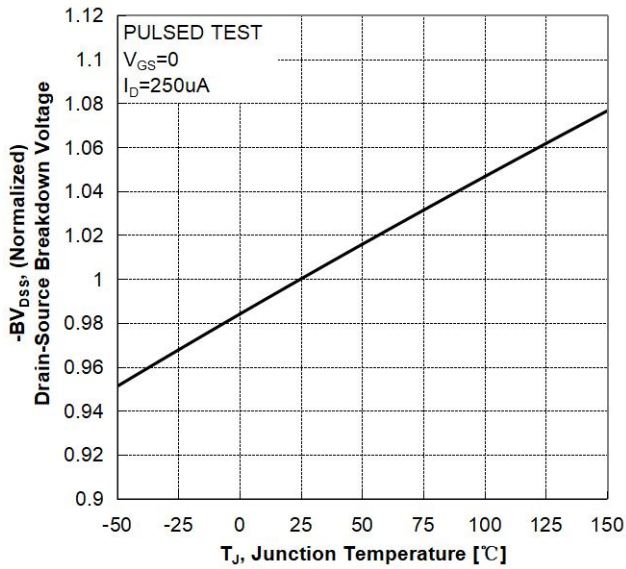

Figure 6 Vth vs Junction Temperature

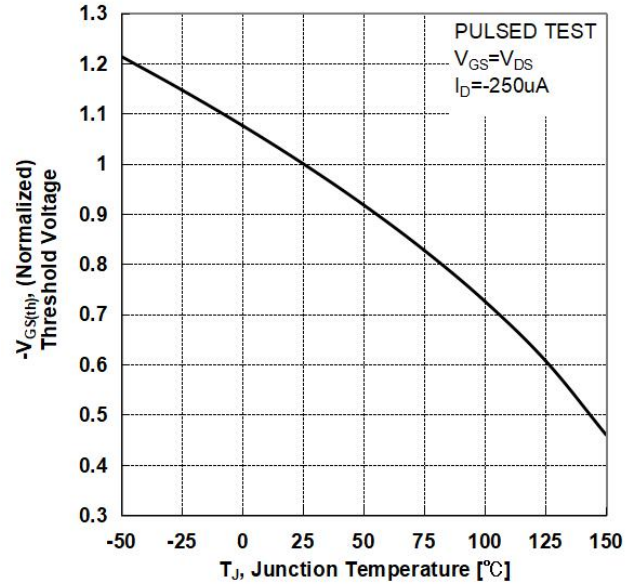

Figure 7 Gate-Charge Characteristics

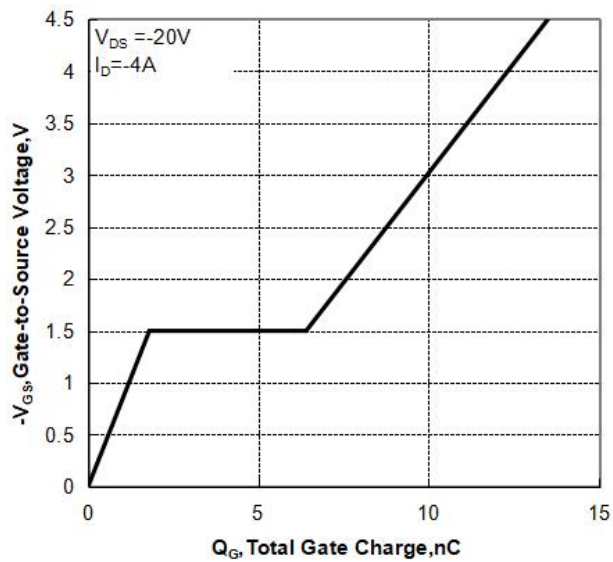

Figure 8 Capacitance Characteristics

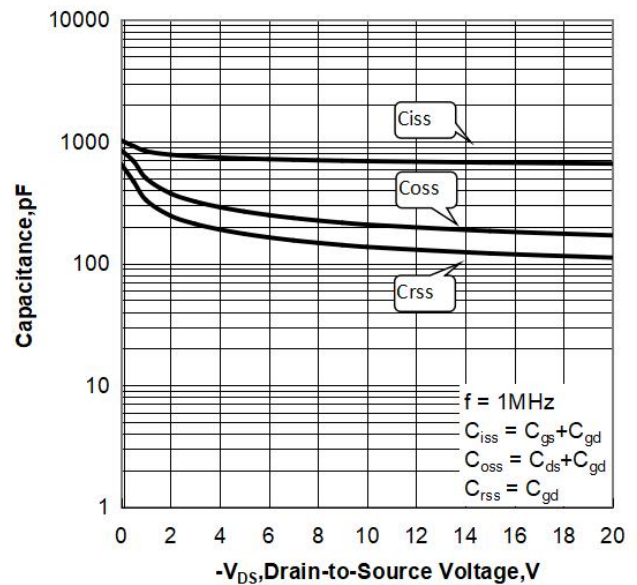

Figure 9 Body Diode Forward Voltage

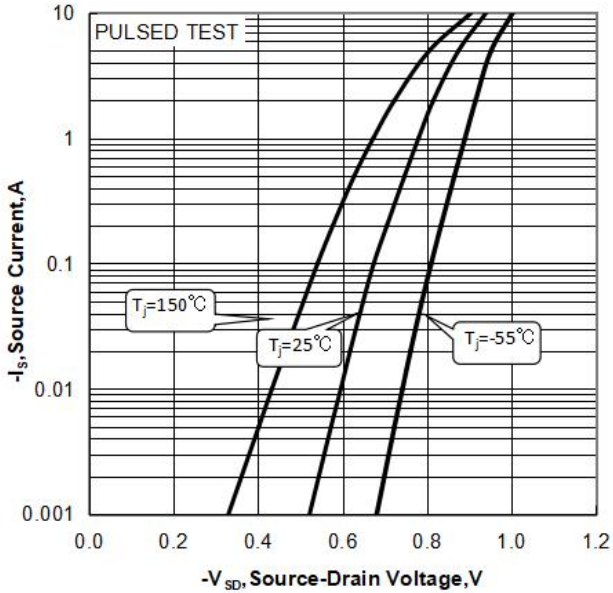

Figure 10 Maximum Safe Operating Area

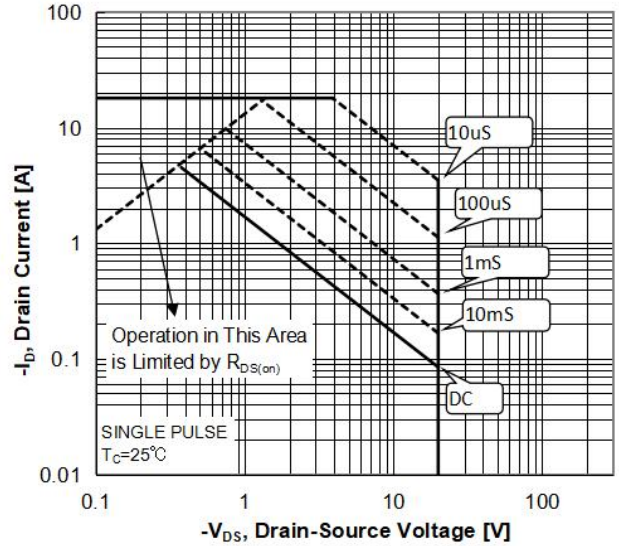
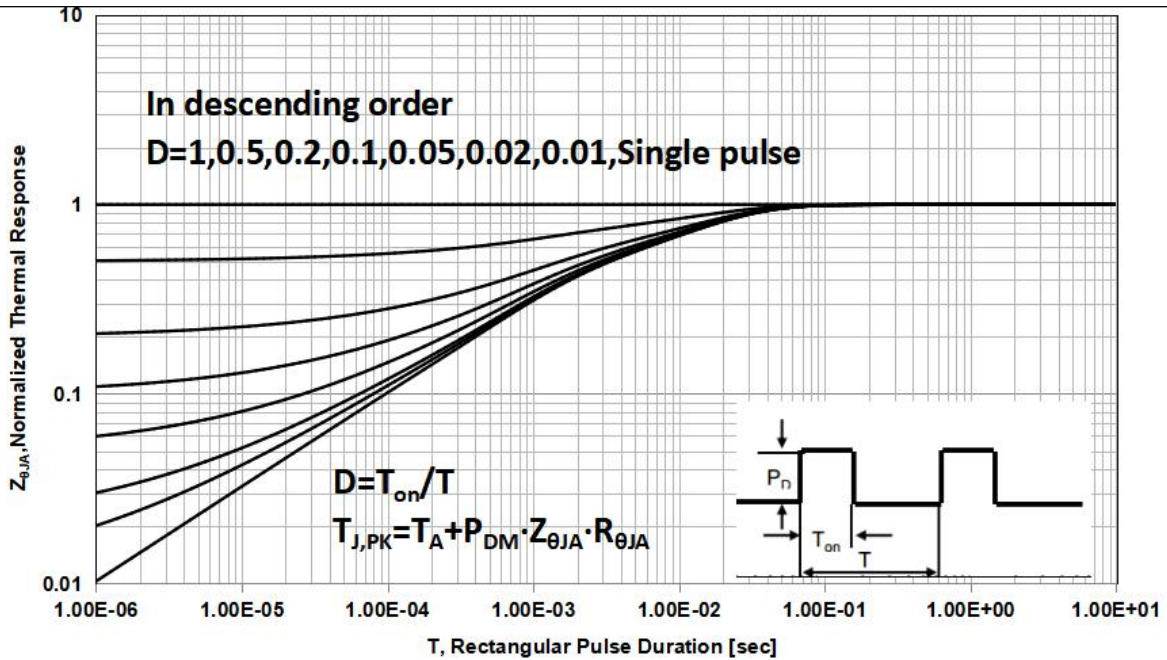
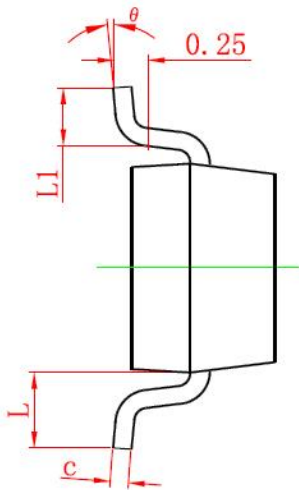
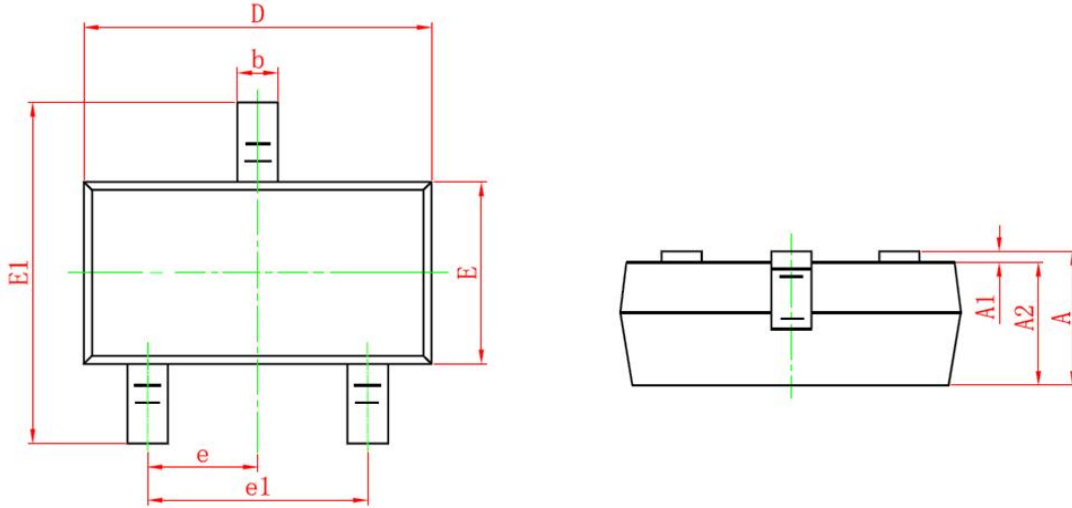

Figure 11 Transient Thermal Impedance



6. Package Description



Symbol	Dimensions in Millimeters	
	MIN.	MAX.
A	0.900	1.150
A1	0.000	0.100
A2	0.900	1.050
b	0.300	0.500
c	0.080	0.150
D	2.800	3.000
E	1.200	1.400
E1	2.250	2.550
e	0.950TYP	
e1	1.800	2.000
L	0.550REF	
L1	0.300	0.500
θ	0°	8°

SOT-23 package

NOTE:

1. Exceeding the maximum ratings of the device in performance may cause damage to the device, even the permanent failure, which may affect the dependability of the machine. Please do not exceed the absolute maximum ratings of the device when circuit designing.
2. When installing the heat sink, please pay attention to the torsional moment and the smoothness of the heat sink.
3. MOSFETs is the device which is sensitive to the static electricity, it is necessary to protect the device from being damaged by the static electricity when using it.
4. Shanghai Belling reserves the right to make changes in this specification sheet and is subject to change without prior notice.

CONTACT:**上海贝岭股份有限公司**

地址：上海市宜山路 810 号

邮编：200233

联系方式：<https://www.belling.com.cn/contact.html>