



## Three-channel linear LED driver with PWM dimming function

### Description

The MEDS92630 is a three-channel linear LED driver with analog and PWM dimming control.

The device's comprehensive fault detection and built-in protection make it ideal for applications with variable intensity LED lighting that can reach the medium power range.

### Applications

- Automotive LED lighting applications, such as: Daytime running lights, parking lights, fog lights, rear lights, parking lights or taillights, interior lighting

### Package

- 16-pin ETSSOP16

### Feature

- AEC-Q100 qualified with the following results:
  - Device temperature Grade1:-40~125°C ambient operating temperature range;
- 3-channel LED driver (with analog and PWM dimming)
- Wide input voltage range: 5V-40V
- Adjustable constant output current set by reference resistor
  - Maximum current: 150mA per channel
  - Maximum current: 450mA in parallel operation mode
  - Accuracy:  $\pm 2\%$  per channel at  $I(\text{IOUTX}) > 30\text{mA}$
  - Accuracy:  $\pm 2.5\%$  per device at  $I(\text{IOUTX}) > 30\text{mA}$
- Use multiple ICs or multiple channels of a single IC in parallel to achieve higher current
- Low voltage drop
  - Maximum voltage drop: 400mV per channel at 60mA
  - Maximum voltage drop: 0.9V per channel at 150mA
  - Each channel performs PWM dimming independently
- Open and short circuit LED detection with anti-burr pulse timer
- Voltage feedback of each channel LED lamp string is used for single LED short circuit detection
- Independent fault pin for single LED short circuit fault

## Typical Application Circuit

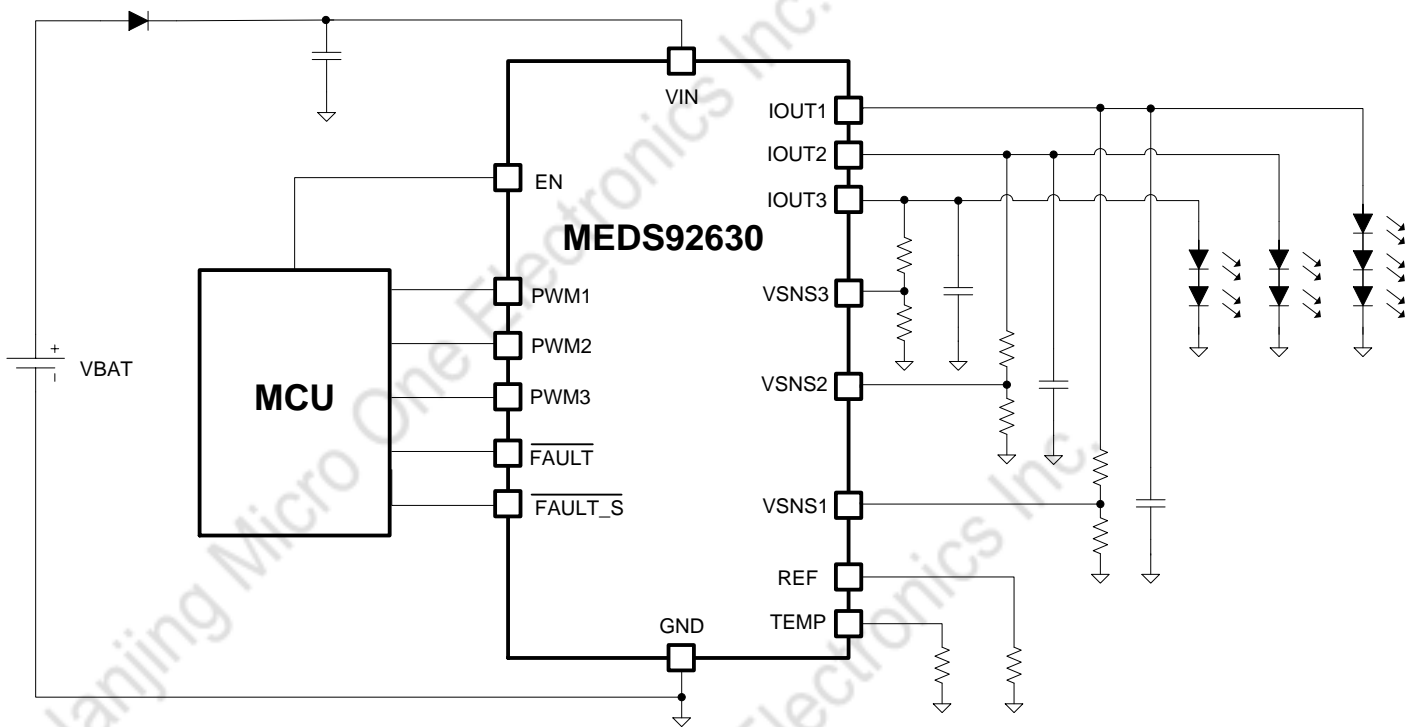

## Selection Guide

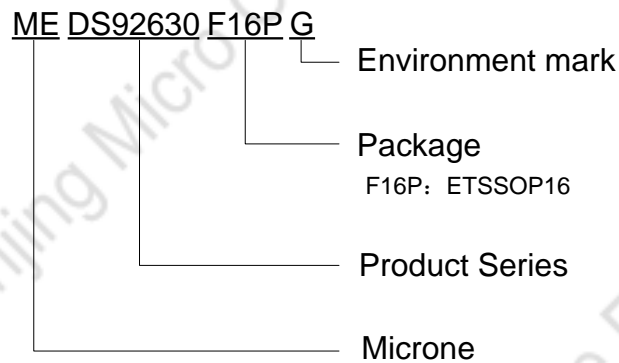

product serie	product description
MEDS92630F16PG	package: ETSSOP16

## Pin Configuration

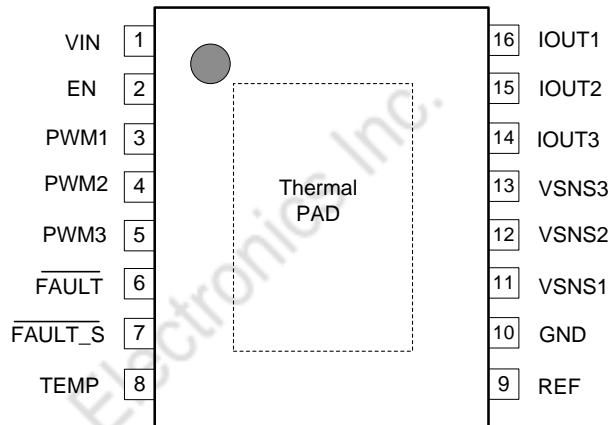

## Pin Assignment

PIN Number	symbol	Function
1	VIN	Input pin – VBAT supply
2	EN	Enable and shut down
3	PWM1	PWM input and channel ON or OFF. Tie to GND if this channel is not used.
4	PWM2	PWM input and channel ON or OFF. Tie to GND if this channel is not used
5	PWM3	PWM input and channel ON or OFF. Tie to GND if this channel is not used
6	$\overline{\text{FAULT}}$	Fault pin. Leave floating if not used.
7	$\overline{\text{FAULT\_S}}$	Single-LED short fault. Leave floating if not used.
8	TEMP	Temperature foldback threshold program. Tie to GND if not used.
9	REF	Reference resistor pin for normal current setting
10	GND	Ground
11	VSNS1	String voltage sense. Connect to IOUT1 if not used.
12	VSNS2	String voltage sense. Connect to IOUT2 if not used.
13	VSNS3	String voltage sense. Connect to IOUT3 if not used.
14	IOUT3	Current output pin. Connect to VSNS2 if not used.
15	IOUT2	Current output pin. Connect to VSNS2 if not used.
16	IOUT1	Current output pin. Connect to VSNS1 if not used.

## Block Diagram

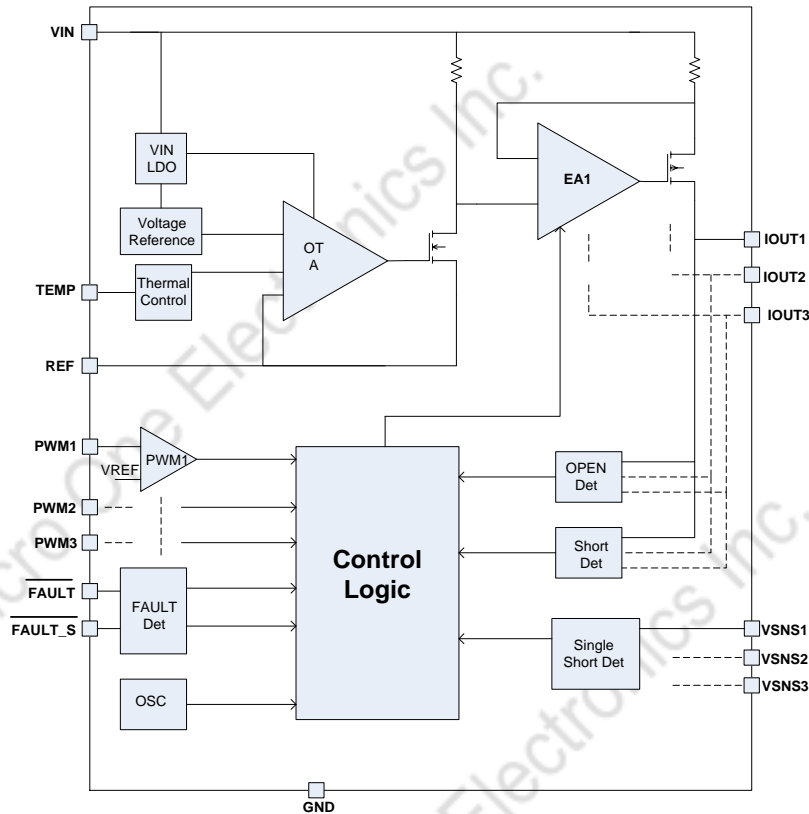

## Absolute Maximum Ratings

Parameter	Symbol	Ratings	Units
VIN supply	VIN	-0.3-40	V
Enable and shut down	EN	-0.3-40	V
Current output pin	IOUTx	-0.3-40	V
String voltage sense	VSNSx	-0.3-40	V
PWM input	PWMx	-0.3-40	V
Fault pin	FAULT	-0.3-40	V
Single-LED short fault	FAULT_S	-0.3-40	V
Reference pin	REF	-0.3-7	V
Temperature foldback	TEMP	-0.3-7	V
Package thermal impedance (Junction to air)	$\theta_{JA}$	54	$^{\circ}\text{C}/\text{W}$
Junction temperature	TJ	-40-150	$^{\circ}\text{C}$
Operating ambient temperature	TA	-40-125	$^{\circ}\text{C}$
Storage temperature	Tstg	-55-150	$^{\circ}\text{C}$

**Note:** Use this IC within the stated maximum ratings. Operation beyond these limits may cause degrading or permanent damage to the device.

## Electrical Characteristic

VIN= 14V, T= -40°C to 150°C (unless otherwise stated)

Parameter	Symbol	Condition	Min	Typ	Max	Unit
<b>SUPPLY VOLTAGE AND CURRENT (VIN)</b>						
Input voltage	VIN		5		40	V
Quiescent current	IQ	All PWMx=high, I(IOUTx)=100 mA, Not including Iref	0.5	0.6	0.85	mA
Shutdown current	IS	V(EN) = 0 V			10	uA
Shutdown current in fault mode(device to GND)	I(fault)	PWM=EN=high, FAULT=low, V(VIN)=5V-40V, I =100mA	0.5	0.6	0.85	mA
Shutdown current in fault mode (from VIN)	I(fault)	PWM=EN=high, FAULT=low, V(VIN)=5V-40V, I=100mA			2	mA
<b>PWMx AND EN</b>						
Logic input, low level	VIL(EN)	IOUTx disabled	0		0.7	V
Logic input, high level	VIH(EN)	IOUTx enabled	2			V
EN internal pulldown	I(EN-pd)	V(EN) =0V to 40 V	0.35		5	uA
Logic input, low level	VIL(PWMx)	IOUTx disabled	1.135	1.195	1.255	V
Logic input, high level	VIH(PWMx)	IOUTx enabled	1.161	1.222	1.283	V
Hysteresis	Vhys(PWM)			44		mV
PWMx internal pulldown current	I(PWM-pd)	V(PWMx)=40V	100	180	250	nA
<b>CURRENT REGULATION (IOUTx)</b>						
Regulated output current range	I(IOUTx)	Each channel	10		150	mA
		Three channels in parallel mode	30		450	mA
Channel accuracy	$\Delta IO(\text{channel})$ (1)	10mA<I(IOUTx)<30mA, V(VIN)=5V-40V	-6		6	%
		30mA≤I(IOUTx)<150mA, Vin=5V-40V	-2		2	%
Device accuracy	$\Delta IO(\text{device})$ (2)	10mA<I(IOUTx)<30mA, V(VIN)=5V-20V	-6		6	%
		30mA≤IOUT<150mA, V(VIN)=5V-20V	-2.5		2.5	%
Reference voltage	Vref		1.198	1.222	1.246	V
Ratio of I(IOUTx) to reference current	K(I)			100		
Dropout voltage	V(DROP)	At 150mA load per channel		0.5	0.9	V
		At 60mA load per channel		0.2	0.4	
Current rise and fall slew rates	SR	Current rising from 10% to 90% or falling from 90% to 10% at I(IOUTx)=60mA	4	8	15	mA/μs
		Current rising from 10% to 90% or falling from 90% to 10% at	7	14	25	mA/μs

		I(IOUTx)=150mA				
<b>FAULT</b>						
Logic input low threshold	VIL				0.7	V
Logic input low threshold	VIH		2			V
Logic output low level	VOL	Tested with 500- $\mu$ A external pullup			0.7	V
Logic output high level	VOH	Tested with 1- $\mu$ A external pulldown	2			V
Strong pulldown current	I(pulldown)		500	700	1000	$\mu$ A
Weak pullup current	I(pullup)		4	8	16	$\mu$ A
<b>COMPARATOR (VSNSx)</b>						
Internal comparator reference (for short circuit detection)	V(VSNSx)	V(VIN) > V(th)	1.198	1.222	1.246	V
Leakage current	I <sub>lkg</sub>	V(VSNSx)=3V			500	nA
Voltage at which the chip enables the single-short alarm function	V(th)	Single-short detection enabled	8		9	V
	V(th) hysteresis			145		mV
<b>PROTECTION</b>						
Open-load detection voltage	V(OLV)	V(OLV) = V(VIN) – V(IOUTx)	50	100	150	mV
Open-load detection hysteresis	V(OL-hys)		100	200	300	mV
Short-detection voltage	V(SV)		0.846	0.89	0.935	V
Short-detection hysteresis			318	335	352	mV
Short-detection deglitch			1	2	3	ms
		During PWM, count the number of continuous cycles when V(IOUTx)<V(SV)	7		8	Cycles
REF pin resistor open detection	R(REF_open)	FAULT goes low	15	23	57	k $\Omega$
REF pin resistor short detection	R(REF_short)	FAULT goes low	350	470	800	$\Omega$
<b>THERMAL MONITOR</b>						
Thermal shutdown	T(shutdown)		155	170	170	$^{\circ}$ C
Thermal shutdown hysteresis	T(hys)			15		$^{\circ}$ C

Thermal foldback activation temperature	T(th)	90% of I(IOUTx) normal (TEMP pin floating)	95	110	125	°C
Minimum foldback current	(TFCmin)		40	50	60	%
Thermal foldback function disable voltage	V(T-disable)			0	0.2	V
<b>Timing Requirements</b>						
Start-up time	t(startup)	V(VIN)>5 V, I(IOUTx)=50%, I(setting)=60mA			200	us
Delay time between PWM rising edge to 10% of I(IOUTx)	td(on)	Two LEDs in series, 10-kΩ resistor in parallel		14	30	us
Delay time between PWM falling edge to 90% of I(IOUTx)	td(off)	Two LEDs in series, 10-kΩ resistor in parallel		25	45	us
Single-short detection deglitch			1	2	3	ms
		During PWM, count the number of continuous cycles when V(VSNSx)<1.24V	7		8	Cycles
Open-load detection deglitch			1	2	3	ms
		During PWM, count the number of continuous cycles when V(VIN) - V(IOUTx) < V(OLV)	7		8	Cycles
Short-detection deglitch			1	2	3	ms
		During PWM, count the number of continuous cycles when V(IOUTx)<V(SV)	7		8	Cycles

$$(1) \text{ channel accuracy} = \frac{I(\text{IOUTx}) - I(\text{avg})}{I(\text{avg})} \quad I(\text{avg}) = \frac{[I(\text{IOUT1}) + I(\text{IOUT2}) + I(\text{IOUT3})]}{3}$$

$$(2) \text{ Device accuracy} = \frac{I(\text{IOUTx}) - I(\text{setting})}{I(\text{setting})} \quad I(\text{setting}) \text{ is the target current set by Rref.}$$

## Typical Performance Characteristics

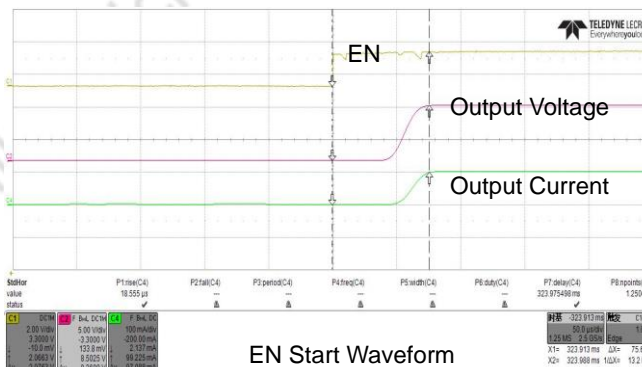
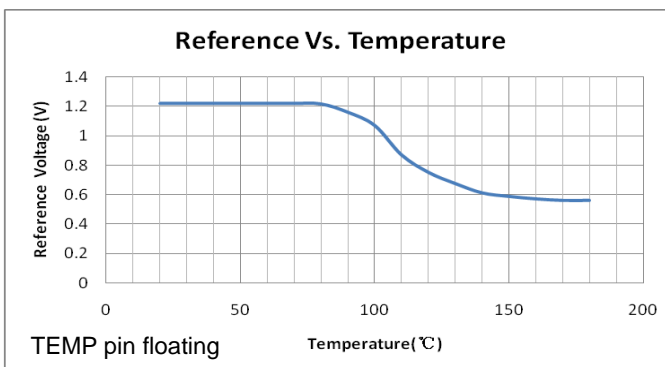
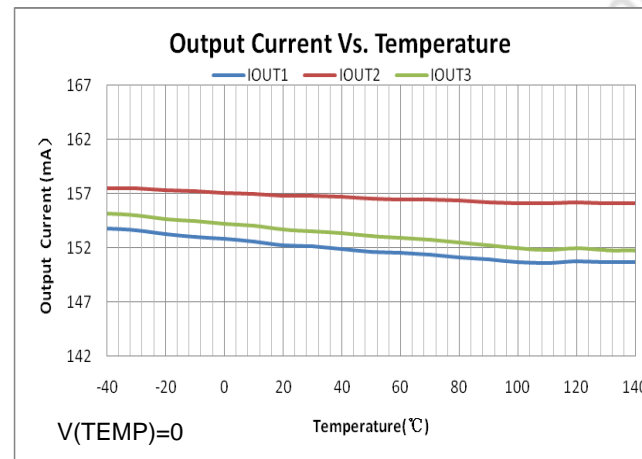
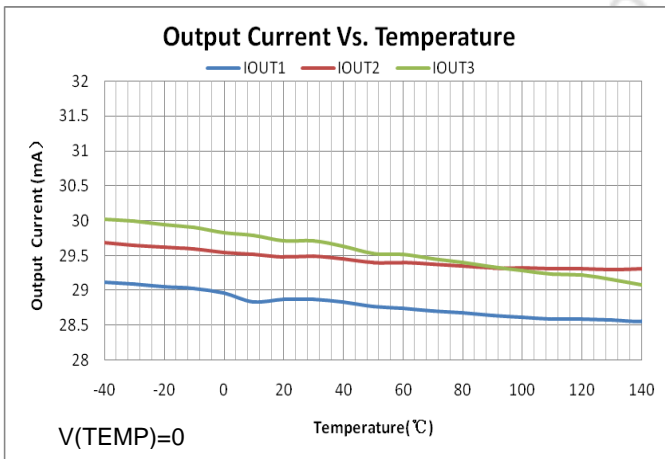
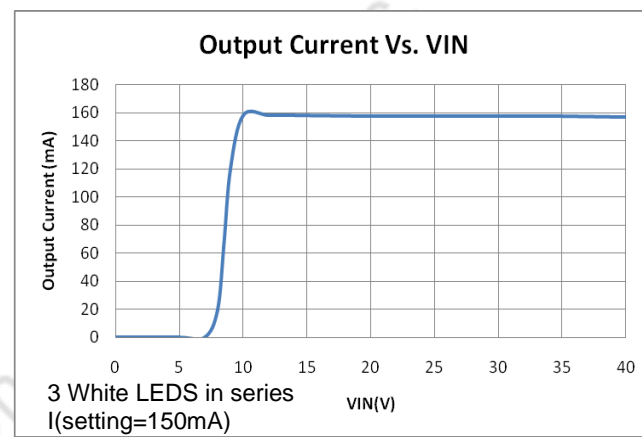
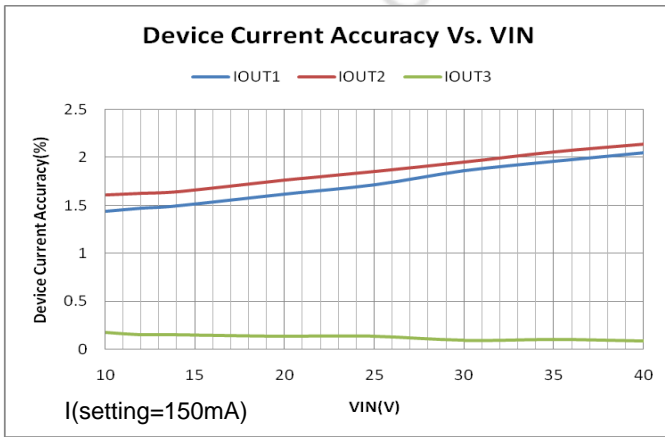
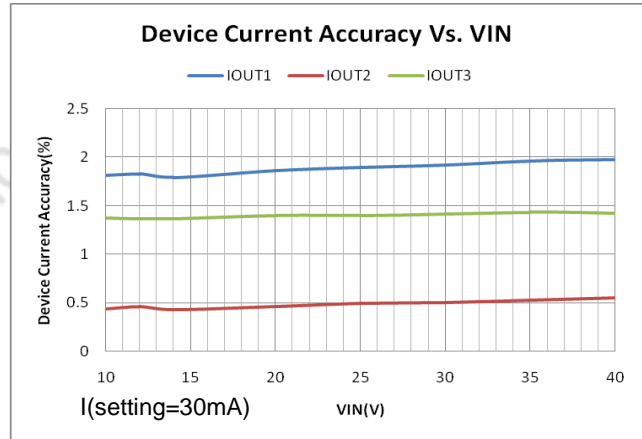
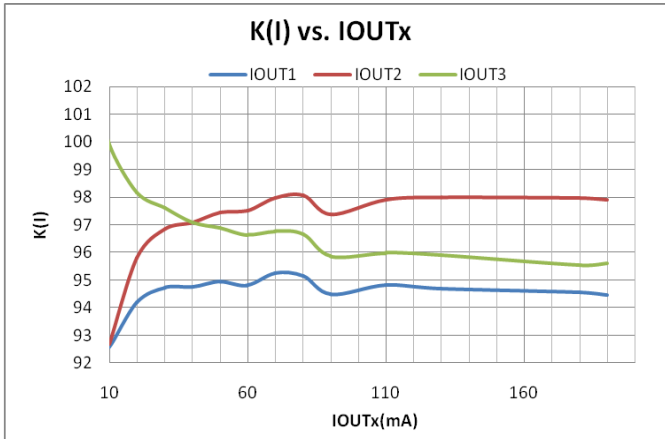



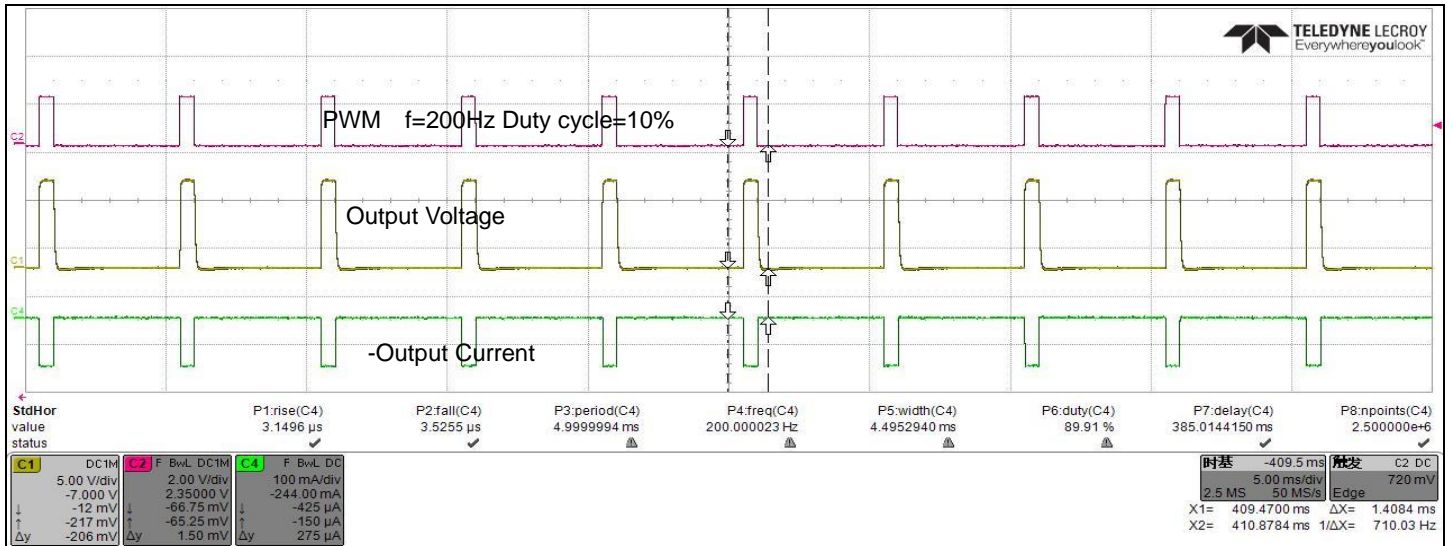

Figure 9. PWM Dimming

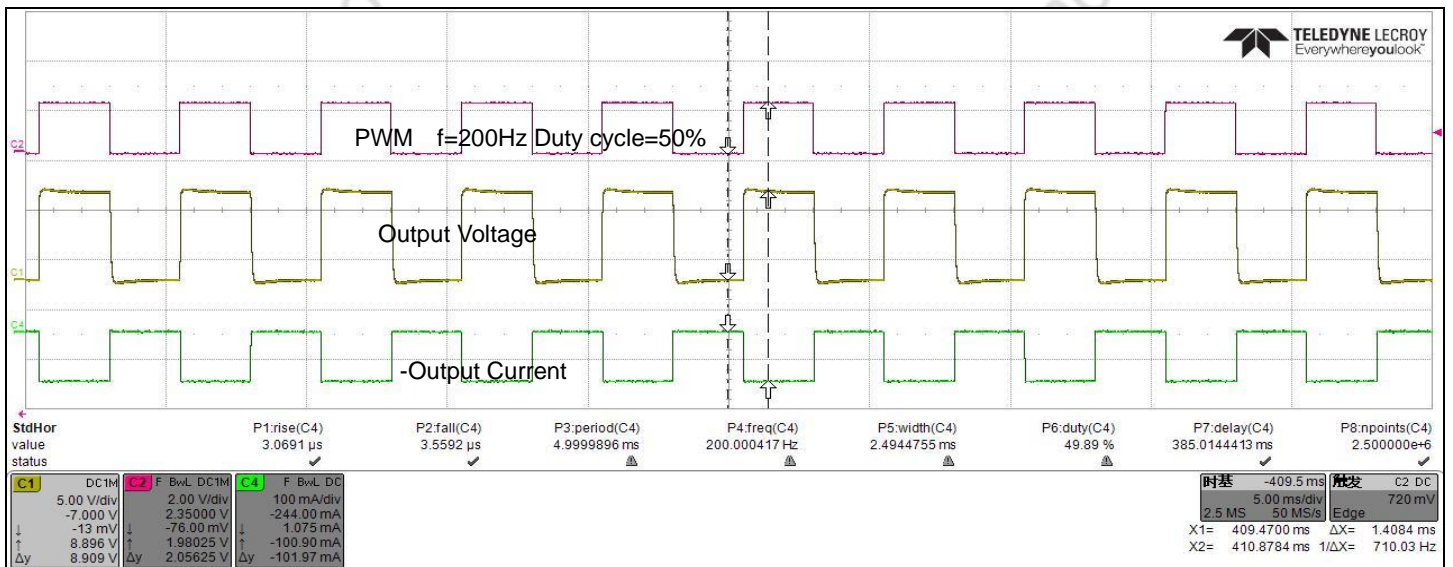

Figure 10. PWM Dimming

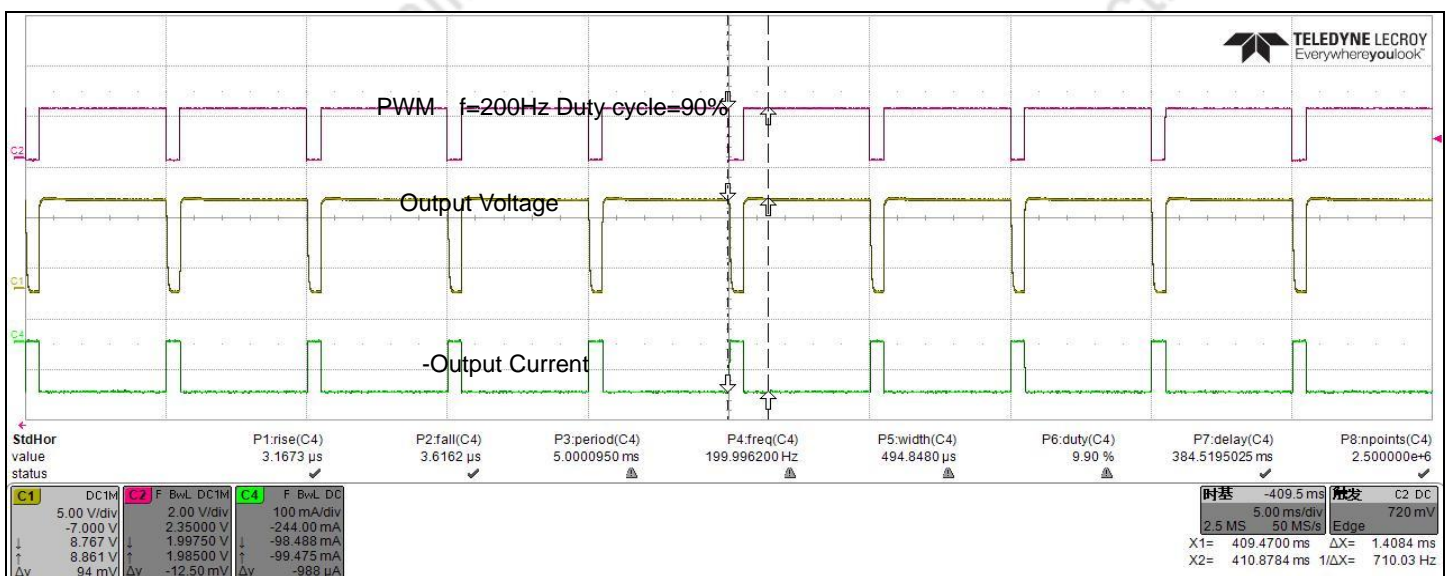

Figure 11. PWM Dimming

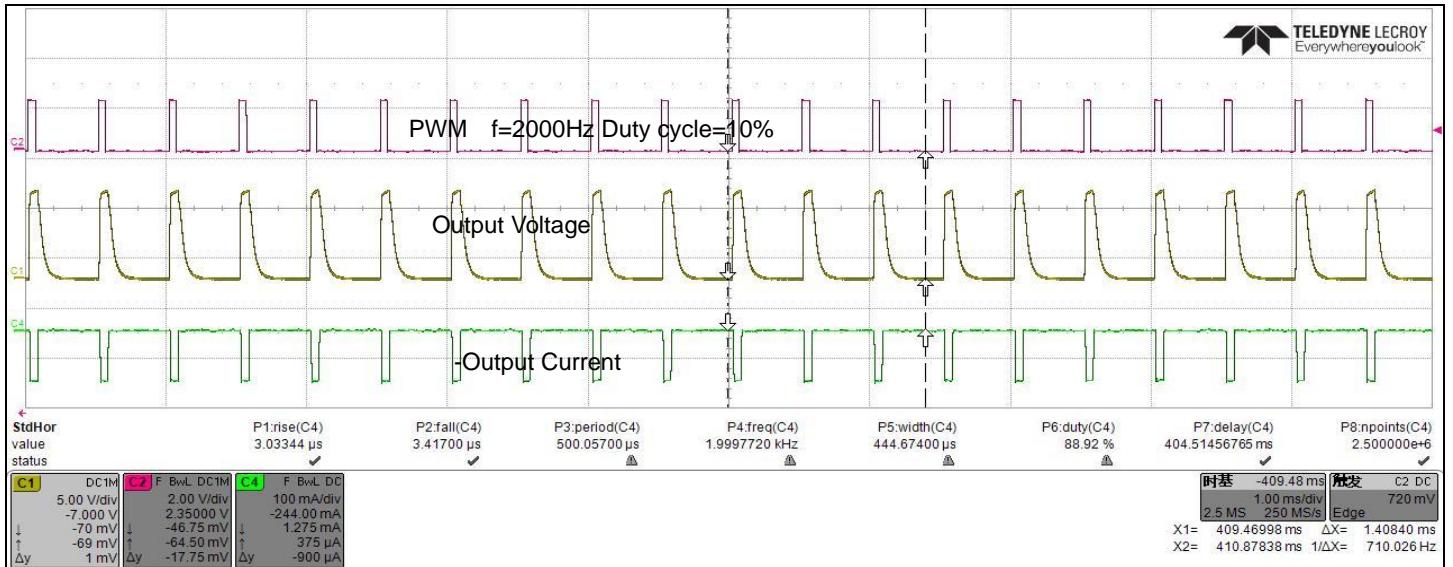

Figure 12. PWM Dimming

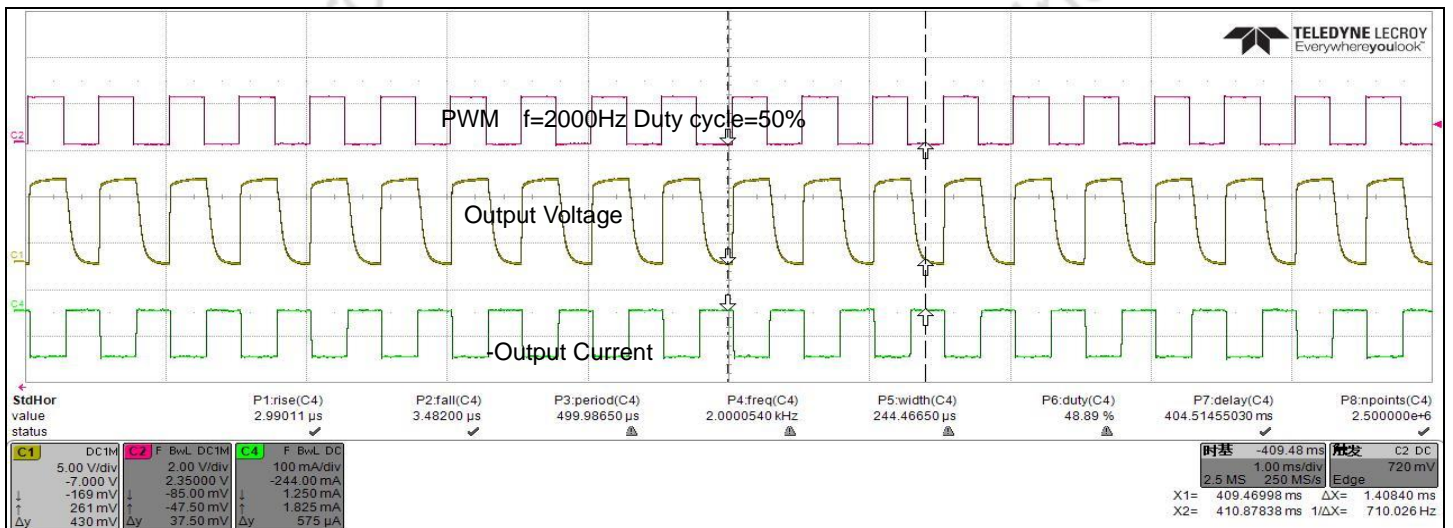

Figure 13. PWM Dimming

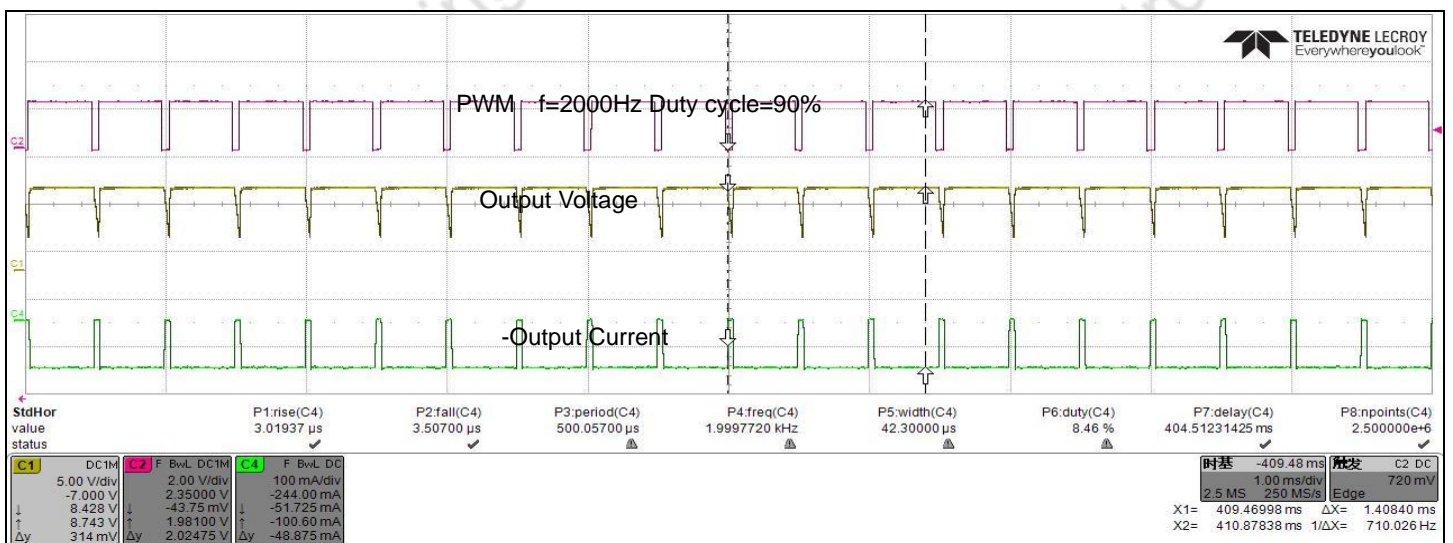

Figure 14. PWM Dimming

## Detailed Description

### Overview

The MEDS92630 device is a three-channel constant-current regulator with individual PWM dimming, designed for high brightness red or white LEDs in automotive lighting applications. Each channel has up to 150mA current capability, giving a combined 450mA current capability when paralleled. The device provides excellent current matching between channels and devices. A high-side current source allows LED common-cathode connections. The advanced control loop allows high accuracy between channels, even when different numbers of LEDs are connected on the output. Use of a separate PWM channel dims or disables each channel.

The MEDS92630 device monitors fault conditions on the output and reports its status on the  $\overline{\text{FAULT}}$  and  $\overline{\text{FAULT\_S}}$  pins. It features single-short-circuit-LED detection, output short-to-ground detection, open-load detection, and thermal shutdown. Two separate fault pins allow maximum flexibility of fault-mode reporting to the MCU in case of an error. In case there is no MCU, one can connect multiple MEDS92630 devices in a bus mode. Integrated thermal foldback protects the devices from thermal shutdown by reducing the output current linearly when reaching a preset threshold. Use an external resistor to program the temperature foldback threshold. Tying the TEMP pin to ground disables this function.

### Feature Description

#### Constant LED-Current Setting

Control of the three LED output channels is through separate linear current regulators. A common external resistor sets the current in each channel. The device also features two current levels with external circuitry, intended for stop-and-tail-light applications.

See Equation 1 on how to set the current:

$$I(\text{IOUT}_x) = \frac{V_{\text{ref}} \times K(I)}{R(\text{REF})} \quad R(\text{REF}) = \frac{V_{\text{ref}} \times K(I)}{I(\text{IOUT}_x)} \quad (1)$$

#### PWM Control

The device features a separate PWM dimming control pin for each output channel. PWM inputs also function as shutdown pin when an output is unused. Tying PWM to ground disables the corresponding output. The PWM signal has a precise threshold, which one can use to define the start-up voltage of LED as an undervoltage-lockout (UVLO) function with the divider resistor from the VIN pin.

#### $\overline{\text{FAULT}}$ Diagnostics

The MEDS92630 device has two fault pins,  $\overline{\text{FAULT}}$  and  $\overline{\text{FAULT\_S}}$ .  $\overline{\text{FAULT\_S}}$  is a dedicated fault pin for single-LED short failure and  $\overline{\text{FAULT}}$  is for general faults, that is, short, open, and thermal shutdown. The dual pins allow maximum flexibility based on all requirements and application conditions. The device fault pins can be connected to an MCU for fault reporting. Both fault pins are open-drain transistors with a weak internal pullup. See Figure 16.

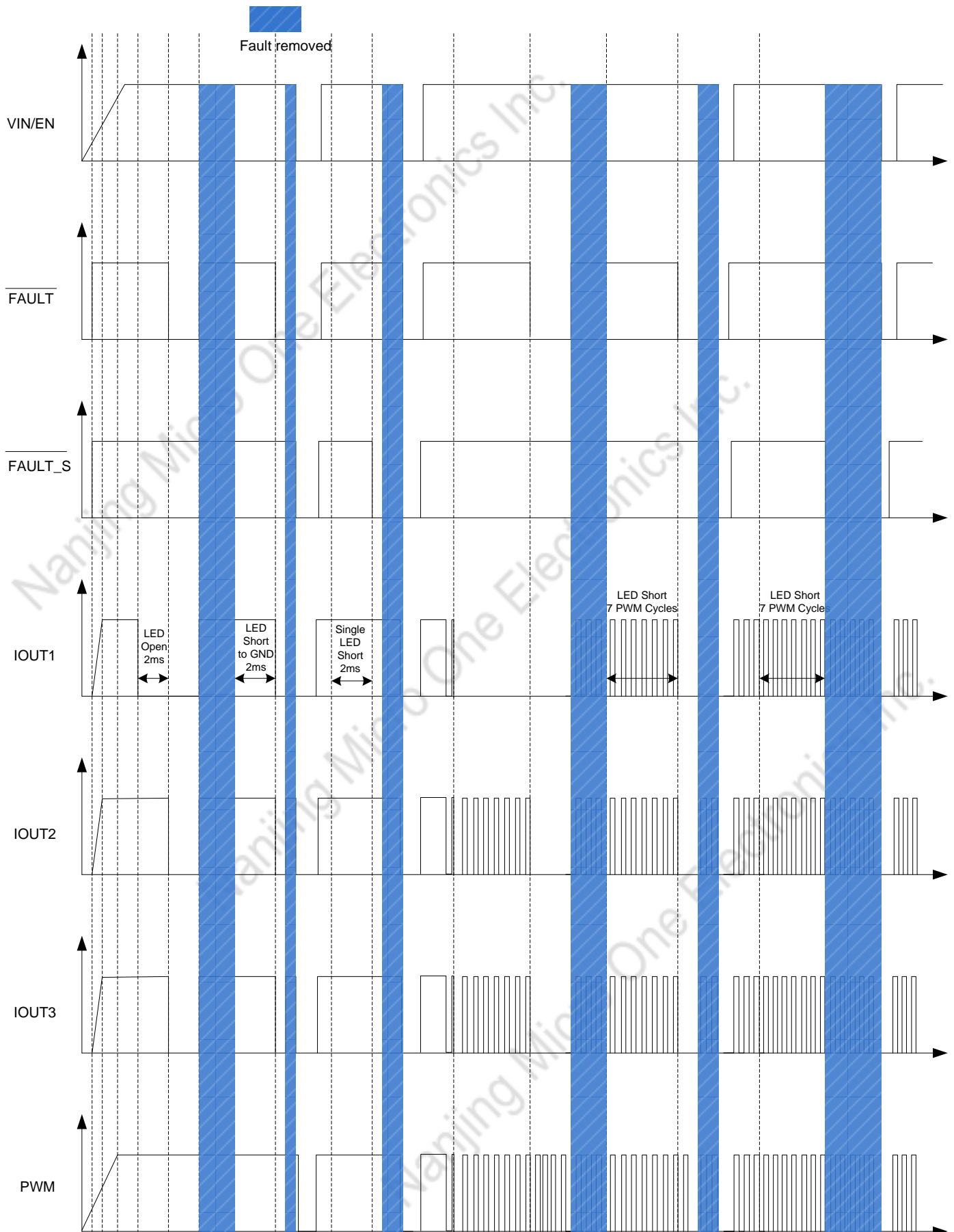

Figure 15. Detailed Timing Diagram

In case there is no MCU, one can connect up to 15 MEDS92630  $\overline{\text{FAULT}}$  and  $\overline{\text{FAULT\_S}}$  pins together. When one or more devices have errors, the respective  $\overline{\text{FAULT}}$  pins go low, pulling the connected  $\overline{\text{FAULT}}$  bus down and shutting down all device outputs. Figure 16 shows the fault-line bus connection.

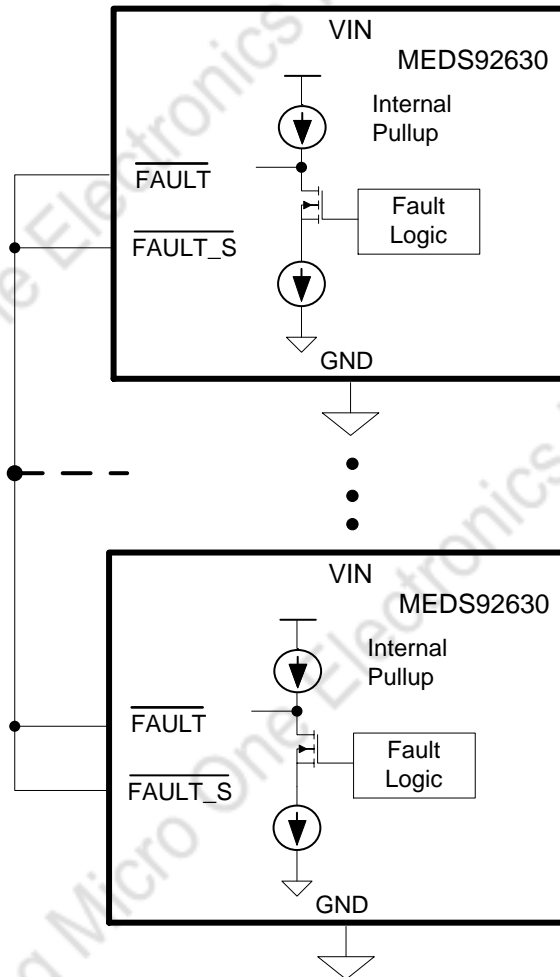

Figure 16. Fault-Line Bus Connection

The device releases the  $\overline{\text{FAULT}}$  bus when external circuitry pulls the  $\overline{\text{FAULT}}$  pin high, on toggling of the EN pin, or on a power cycle of the device. In case there is no MCU, only a power cycle clears the fault. See Figure 17.

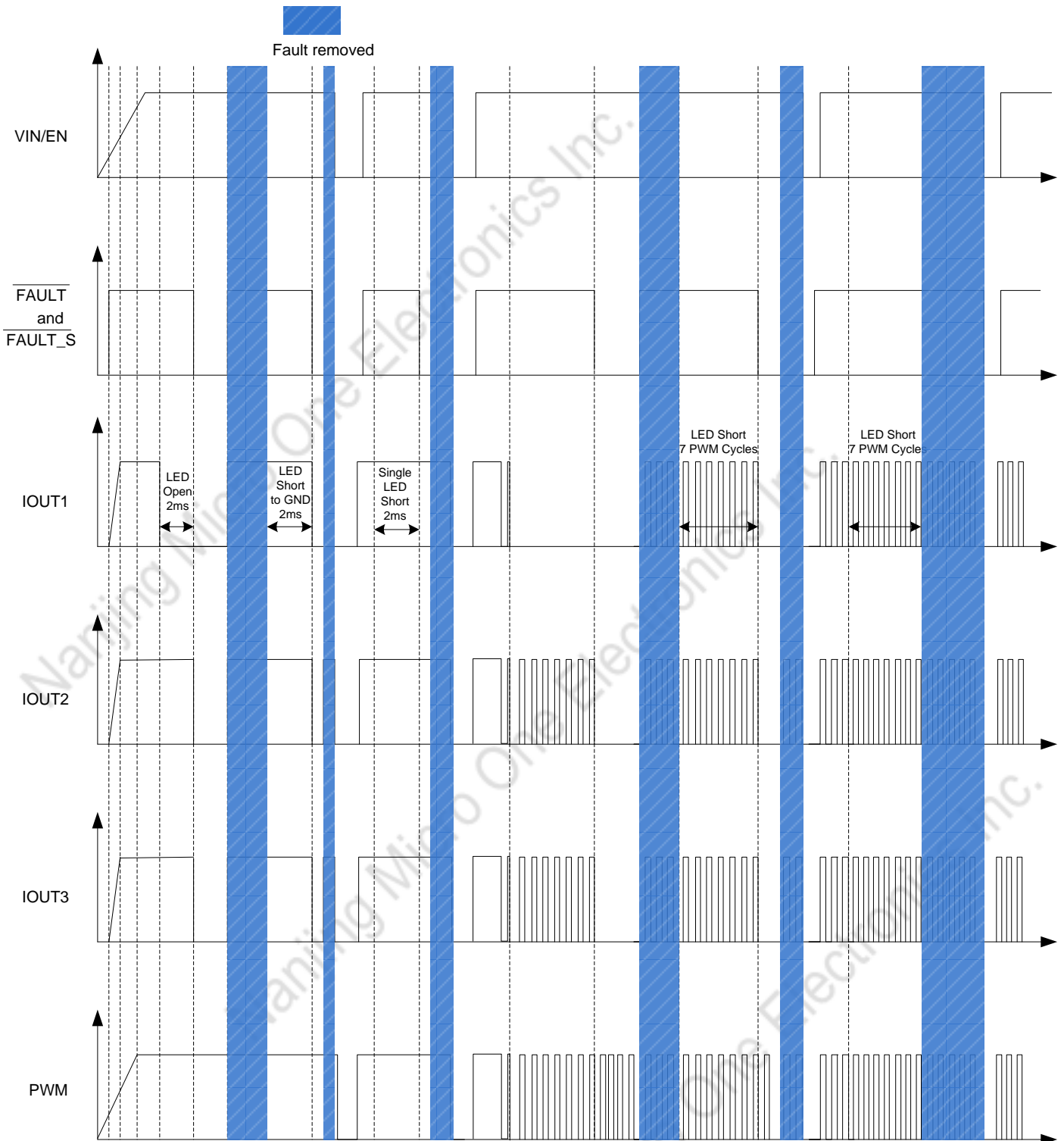

Figure 17. Detailed Timing Diagram

The following faults result in the  $\overline{\text{FAULT}}$  or  $\overline{\text{FAULT\_S}}$  pin going low: thermal shutdown, open load, output short circuit, single LED short, and REF open or shorted. For thermal shutdown or LED open, release of the  $\overline{\text{FAULT}}$  pin occurs when the thermal-shutdown or LED-open condition no longer exists. For other faults, the  $\overline{\text{FAULT}}$  and  $\overline{\text{FAULT\_S}}$  pins stay low even if the condition does not exist. Clearing the faults requires a power cycle of the device.

### Short-Circuit Detection

The device includes three internal comparators for LED forward-voltage measurement. With external resistor dividers, the device compares total LED forward voltage with the internal reference voltage. This feature enables the detection of one or more shorted LEDs. Any LED cathode or IOU<sub>Tx</sub> pin shorted to ground results in a short-circuit condition. The external resistor dividers control the detection-threshold-voltage setting.

Figure 18 illustrates different short-circuit conditions.

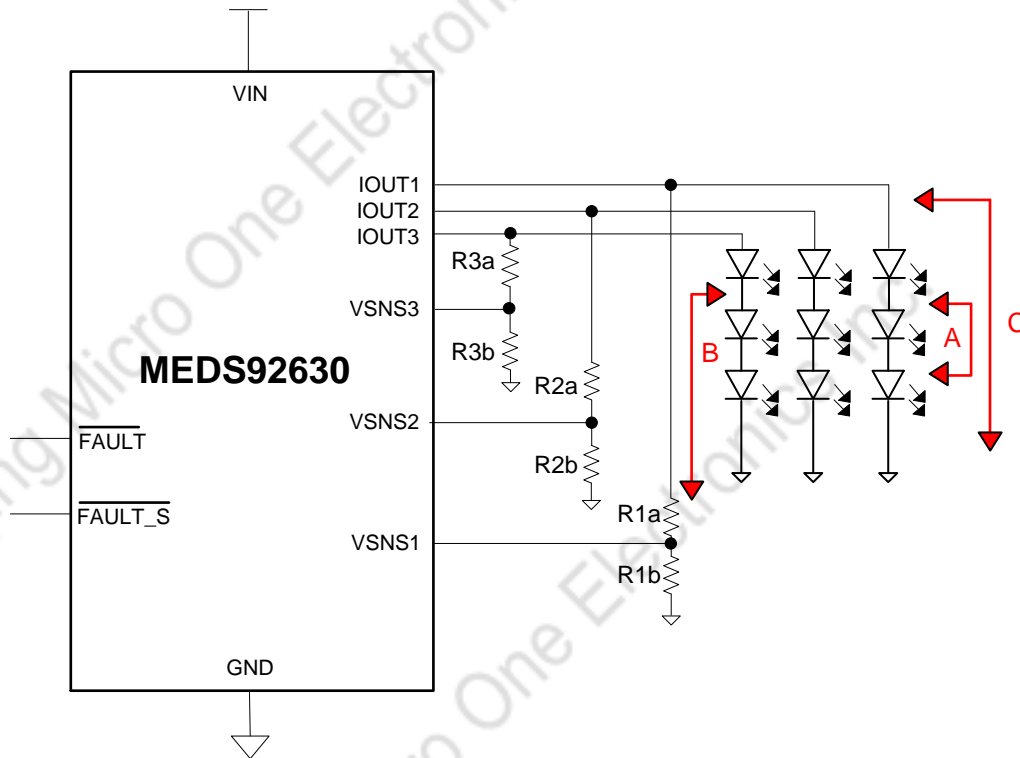

Figure 18. Short-Circuit Cinditions

A short in one or more LEDs in a string (A and B as illustrated) registers as only a single-LED short when  $V_{(VIN)} > 9V$ .

- The device reports the failure to the MCU. The faulted channel continues sourcing current until the MCU takes actions to turn off channels through the EN or PWM<sub>x</sub> pin.
- No MCU: with  $\overline{FAULT\_S}$  floating, no action results. With  $\overline{FAULT\_S}$  tied to  $\overline{FAULT}$ , all output channels shut down together.

When an entire string of LEDs is shorted (C as illustrated), the device pulls  $\overline{FAULT}$  low to shut down all channels.

With the  $\overline{FAULT}$  pin tied high, only the faulted channel turns off.

- $V_{F(max)}$  – maximum forward voltage of LED used
- $V_{F(min)}$  – minimum forward voltage of LED used
- N – Number of LEDs used in a string
- R – resistor divider ratio
- $V_{(VSNSx)}$  – internal reference voltage of comparators

When selecting R, observe the following relationship to avoid false triggering.

$$R = (R_{xa} + R_{xb}) / R_{xb} \quad (2)$$

$$(N - 1) \times V_{F(max)} < V_{(VSNSx)} \times R < N \times V_{F(min)} \quad (3)$$

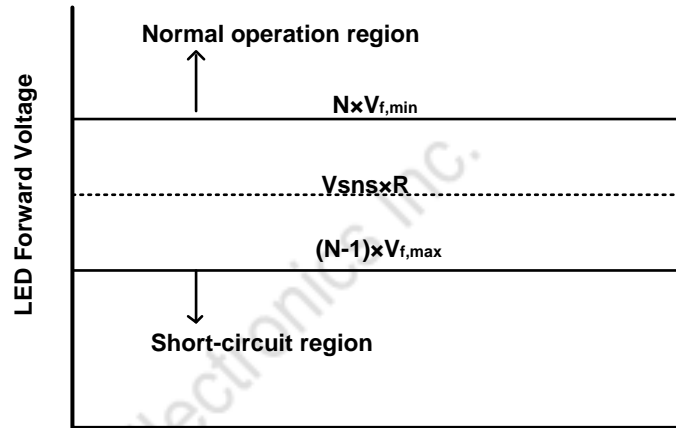

Figure 19. Single-LED Short-Trigger Calculation

**Open-Load Detection**

Detection of an open-load condition occurs when the voltage across the channel,  $V_{(VIN)} - V_{(IOUTx)}$ , is less than the open-load detection voltage,  $V_{(OLV)}$ . When this condition is present for more than the open-load-detection deglitch (2ms when PWM is 100% on or one PWM on-time is more than 2ms, or seven continuous PMW duty cycles when in PWM dimming mode), the  $\overline{FAULT}$  pin goes low, keeping the open channel on and turning the other channel off. With the  $\overline{FAULT}$  pin tied high, all channels remain turned on. The channel recovers on removal of the open condition. Note that the device can detect an open load if the sum of the forward voltages of the LEDs in a string is close to or greater than the supply voltage on VIN.

**Table 1. Fault Table (1)(2)**

FAILURE MODE	JUDGMENT CONDITION			DIAGNOSTIC OUTPUT PINS	ACTION	FAULT AND FAULT_S <sup>(3)</sup>	DEVICE REACTION	FAILURE REMOVED	SELF-CLEARING
	DETECT ON VIN VOLTAGE	CHANNEL STATUS	DETECTION MECHANISM						
<b>Short circuit:</b> 1 or several LED strings	$V_{(VIN)} > 5V$	ON	$V_{(IOUTx)} < 0.9V$	$\overline{FAULT}$	Pulled low	Externally pulled high	Failing strings turned off, other channels on	Toggle EN, power cycle	NO
						Floating	All strings turned OFF	Toggle EN, power cycle	
<b>Single-LED short circuit:</b> 1 or several LED strings	$V_{(VIN)} > 9V$	ON	$V_{(VSNsx)} < 1.222V$	$\overline{FAULT\_S}$	Pulled low	Externally pulled high	All strings stay ON	Toggle EN, power cycle	NO
						Floating	All strings stay ON	Toggle EN, power cycle	
<b>Open load:</b> 1 or several LED strings	$V_{(VIN)} > 5V$	ON	$V_{(VIN)} - V_{(IOUTx)} < 100mV$	$\overline{FAULT}$	Pulled low	Externally pulled high	All strings stay ON		YES
						Floating	Failing string stays ON, other channels turned OFF		
<b>Short to battery:</b> 1 or several LED strings	$V_{(VIN)} > 5V$	ON or OFF	$V_{(VIN)} - V_{(IOUTx)} < 100mV$	$\overline{FAULT}$	Pulled low	Externally pulled high	All strings stay ON		YES
						Floating	Failing string stays ON, other channels turned OFF		
<b>Thermal shutdown</b>	$V_{(VIN)} > 5V$	ON or OFF	Temperature $> 170^{\circ}C$	$\overline{FAULT}$	Pulled low	Externally pulled high Leave open	All strings turned OFF	Temperature $< 155^{\circ}C$	YES
<b>Thermal foldback</b>	$V_{(VIN)} > 5V$	ON or OFF	Temperature $> 110^{\circ}C$	NA	None	NA	All strings with reduced current	Temperature $< 100^{\circ}C$	YES
<b>Reference resistor Open or shorted</b>	$V_{(VIN)} > 5V$	ON or OFF	$R_{(REF)} > 57 k\Omega$ or $R_{(REF)} < 350 \Omega$	$\overline{FAULT}$	Pulled low	NA	All strings turned OFF	Toggle EN, power cycle	NO

(1) With diagnostic pins  $\overline{FAULT}$  and  $\overline{FAULT\_S}$  tied high externally, pullup must be strong enough to override



internal pulldown.

(2) To achieve single-LED short circuit to turn off all strings,  $\overline{\text{FAULT\_S}}$  and  $\overline{\text{FAULT}}$  pins must be connected together.

(3) Pulling  $\overline{\text{FAULT}}$  and  $\overline{\text{FAULT\_S}}$  high externally changes the behavior of the device reaction. If not externally forced high, the device pulls the pins low based on the failure mode.

### Thermal Foldback

The MEDS92630 device integrates thermal shutdown protection to prevent the device from overheating. In addition, to prevent LEDs from flickering because of rapid thermal changes, the device includes a programmable thermal current-foldback feature to reduce power dissipation at high junction temperatures. The MEDS92630 device reduces the LED current as the silicon junction temperature of the MEDS92630 device increases (see Figure 20). By mounting the MEDS92630 device on the same thermal substrate as the LEDs, use of this feature can also limit the dissipation of the LEDs. As the junction temperature of the MEDS92630 device increases, the device reduces the regulated current, reducing the dissipated power in the MEDS92630 device and in the LEDs. The current reduction is from the 100% level at typically 2% of  $I_{(\text{setting})}$  per °C until the point at which the current drops to 50% of the full value.

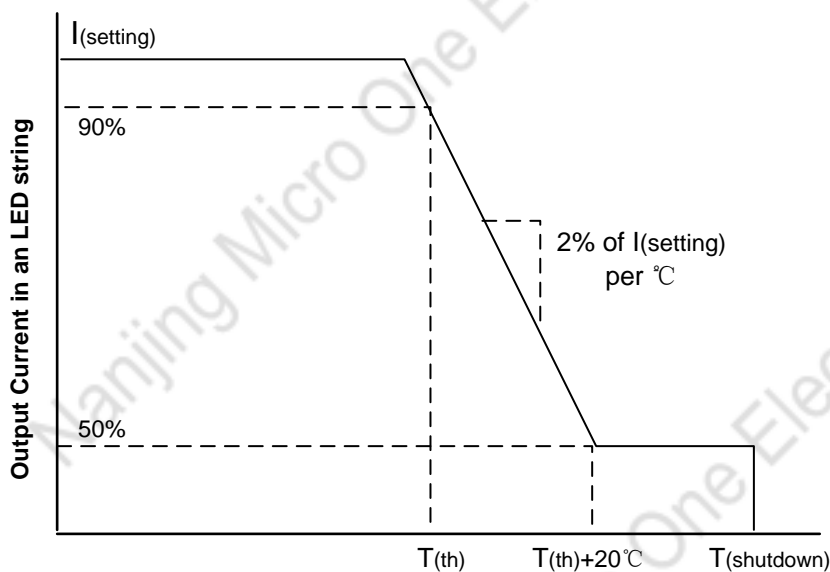

Figure 20. Thermal Foldback

Above this temperature, the current continues to decrease at a lower rate until the temperature reaches the overtemperature shutdown threshold temperature,  $T_{(\text{shutdown})}$ . Changing the voltage on the TEMP pin adjusts the temperature at which the current reduction begins. With TEMP floating, the definition of thermal monitor activation temperature,  $T_{(\text{th})}$ , is the temperature at which the current reduction begins. The specification of  $T_{(\text{th})}$  in the characteristics table is at the 90% current level.  $T_{(\text{th})}$  increases as the voltage at the TEMP pin,  $V_{(\text{TEMP})}$ , declines

and is defined as approximately:

$$T_{(th)} = -121.7V_{(TEMP)} + 228.32$$

A resistor connected between TEMP and GND reduces  $V_{(TEMP)}$  and increases  $T_{(th)}$ . A resistor connected between TEMP and a reference supply greater than 1 V increases  $V_{(TEMP)}$  and reduces  $T_{(th)}$ .

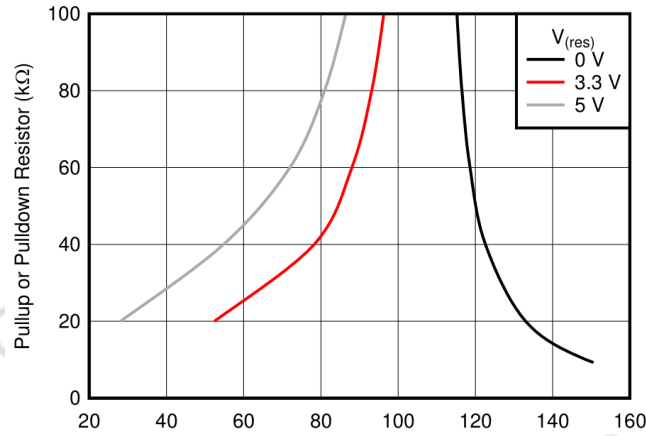

Figure 21. Pullup and Pulldown Resistors vs T<sub>(th)</sub>

Figure 21 shows how the nominal value of the thermal-monitor activation temperature varies with the voltage at TEMP and with either a pulldown resistor to GND or with a pullup resistor to 3.3 V or 5 V.

In extreme cases, if the junction temperature exceeds the overtemperature limit,  $T_{(shutdown)}$ , the device disables all channels. Temperature monitoring continues, and channel reactivation occurs when the temperature drops below the threshold provided by the specified hysteresis.

Note the possibility of the MEDS92630-Q1 device transitioning rapidly between thermal shutdown and normal operation. This can happen if the thermal mass attached to the exposed thermal pad is small and  $T_{(th)}$  is increased to close to the shutdown temperature. The period of oscillation depends on  $T_{(th)}$ , the dissipated power, the thermal mass of any heatsink present, and the ambient temperature.

### Device Functional Modes

#### Thermal Information

This device operates a thermal shutdown (TSD) circuit as a protection from overheating. For continuous normal operation, the junction temperature should not exceed the thermal-shutdown trip point. If the junction temperature exceeds the thermal-shutdown trip point, the output turns off. When the junction temperature falls below the thermal-shutdown trip point, the output turns on again.

Calculate the power dissipated by the device according to the following formula:

$$P_T = V_{(VIN)} \times I_{(VIN)} - n1 \times V_{(LED1)} \times I_{(LED1)} - n2 \times V_{(LED2)} \times I_{(LED2)} - n3 \times V_{(LED3)} \times I_{(LED3)} - V_{ref}^2/R_{(REF)} \quad (5)$$

where:

$P_T$  = Total power dissipation of the device

$n_x$  = Number of LEDs for channel x

$V_{(LEDx)}$  = Voltage drop across one LED for channel x

$V_{ref}$  = Reference voltage, typically 1.222V

$I_{(LEDx)}$  = Average LED current for channel x

After determining the power dissipated by the device, calculate the junction temperature from the ambient temperature and the device thermal impedance.

$$T_J = T_A + R_{\theta JA} \times P_T \quad (6)$$

#### Operation With $V_{(VIN)} < 5V$ (Minimum $V_{(VIN)}$ )

The devices operate with input voltages above 5 V. The devices start working when  $V_{(VIN)} > 4 V$ , but while  $4 V < V_{(VIN)} < 5 V$ , the devices shield all the fault status. With fault status shielded, if any fault occurs the devices may not report the fault and take the correct action.

#### Operation With $5V < V_{(VIN)} < 9 V$ (Lower-Than-Normal Automotive Battery Voltage)

The devices operate with input voltages above 5 V. When the input voltage is lower than normal automotive 9 V, the devices shield single-LED-short fault status. With fault status shielded, if a single-LED-short fault occurs the devices do not report the fault with the  $\overline{FAULT\_S}$  pin.

### Layout

#### Layout Guidelines

In order to prevent thermal shutdown,  $T_J$  must be less than 150°C. If the input voltage is very high, the power dissipation might be large. The devices are currently available in the TSSOP-EP package, which has good thermal impedance. However, the PCB layout is also very important. Good PCB design can optimize heat transfer, which is absolutely essential for the long-term reliability of the device.

- Maximize the copper coverage on the PCB to increase the thermal conductivity of the board, because the major heat-flow path from the package to the ambient is through the copper on the PCB. Maximum copper is extremely important when the design does not include heat sinks attached to the PCB on the other side of the package.
- Add as many thermal vias as possible directly under the package ground pad to optimize the thermal conductivity of the board.
- All thermal vias should be either plated shut or plugged and capped on both sides of the board to prevent solder voids. To ensure reliability and performance, the solder coverage should be at least 85 percent.

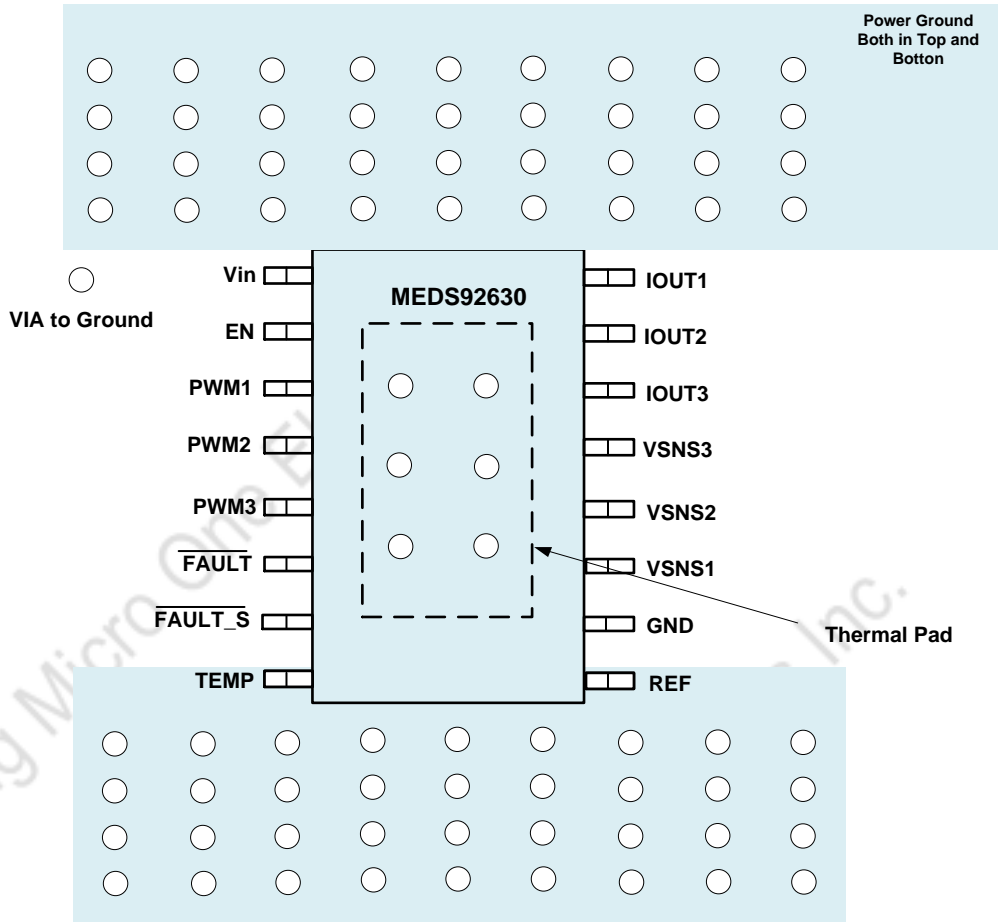

Figure 22.MEDS92630 Board Layout

**Package Quantity**

Package Type	Minimum Packing QTY	UNITS	Small Box	Large BOX
ETSSOP16	5000	Tape & Reel	10K	80K

## Package Information

- Package type: ETSSOP16

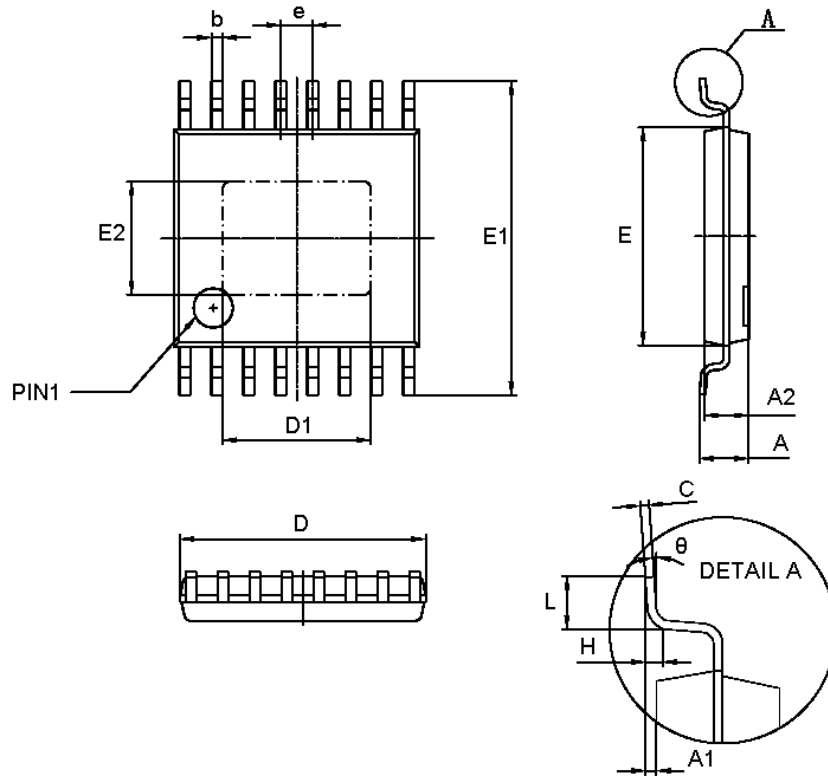

DIM	Millimeters		Inches	
	Min	Max	Min	Max
A		1.2	0.0000	0.0472
A1	0.02	0.15	0.0008	0.0059
A2	0.8	1.05	0.0315	0.0413
b	0.19	0.3	0.0075	0.0118
c	0.09	0.2	0.0035	0.0079
D	4.9	5.1	0.1929	0.2008
E	4.3	4.5	0.1693	0.1772
D1	2.8	3.1	0.1102	0.1220
E1	6.2	6.6	0.2441	0.2598
E2	2.1	2.4	0.0827	0.0945
e	0.65BSC		0.0256	
$\theta$	0	8°	0	8°
L	0.45	0.75	0.0177	0.0295

- The contents of this document will be updated with the product's improvement without prior notice. Please consult our sales staff before using this document to ensure that you are using the latest version.
- The application circuit examples described in this document are only used to indicate the representative use of the product and do not guarantee the design of mass production.
- Please use this product within the limits stated in this document. We will not be responsible for any damage caused by improper use.
- The products described in this document are not allowed to be used in equipment or devices that affect the human body without the written permission of our company, including but not limited to: health equipment, medical equipment, disaster prevention equipment, fuel control equipment, automobile equipment, aviation equipment and vehicle equipment.
- Although our company has always been committed to improving product quality and reliability, semiconductor products have a certain probability of malfunction or wrong work. To prevent personal injury or property damage caused by such accidents, please pay full attention to safety design, for example: Alternate design, fire protection design, and prevention of wrong action design.
- When exporting this product or this document overseas, you should abide by applicable import and export control laws.
- Copying or reprinting part or all of this document in any form without the permission of our company is strictly prohibited.